

# EA6-4AT/EUT

## 系列高速包缝机

EA6-4AT/EUT SERIES  
HIGH-SPEED OVERLOCK  
SEWING MACHINE

使用说明书  
OPERATION MANUAL

零件手册  
PARTS BOOK

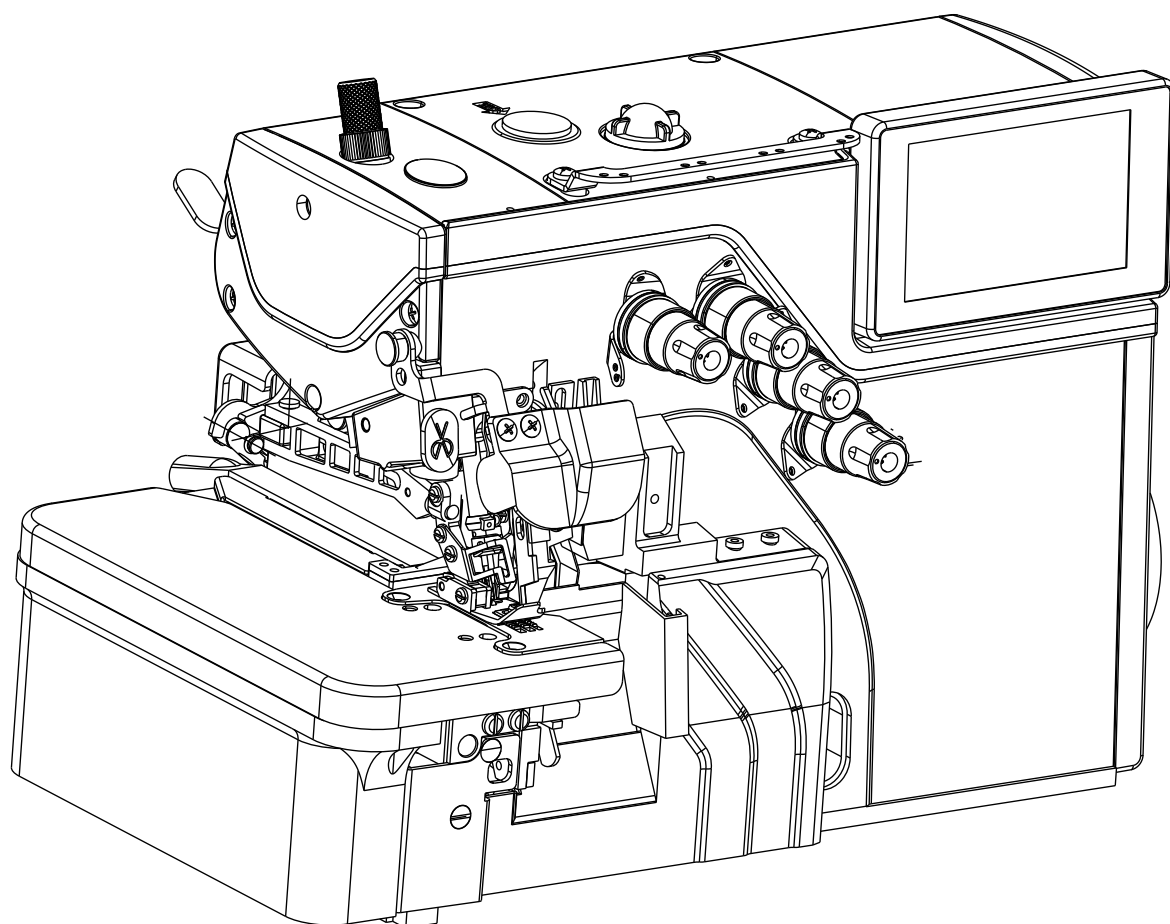

# IMPORTANT SAFETY INSTRUCTIONS

To get the most out of the many functions of this machine and operate it in safety, it is necessary to use this machine correctly. Please read this Instruction Manual carefully before use. We hope you will enjoy the use of your machine for a long time. Please remember to keep this manual in a safe place.

1. Observe the basic safety measures, including, but not limited to the following ones, whenever you use the machine.
2. Read all the instructions, including, but not limited to this Instruction Manual before you use the machine, in addition, keep this Instruction Manual so that you may read it at any-time when necessary.
3. Use the machine after it has been ascertained that it conforms with safety rules/standards valid in your country.
4. All safety devices must be in position when the machine is ready for work or in operation. The operation without the specified safety devices is not allowed.
5. This machine shall be operated by appropriately-trained operators.
6. For your personal protection, we recommend that you wear safety glasses.
7. For the following, turn off the power switch or disconnect the power plug of the machine from the receptacle.
  - 7-1 For threading needle(s) and replacing bobbin.
  - 7-2 For replacing part(s) of needle, presser foot, throat plate, feed dog, cloth guide etc.
  - 7-3 For repair work.
  - 7-4 For when leaving the working place or when the working place is unattended.
8. If you should allow oil, grease, etc. used with the machine and devices to come in contact with your eyes or skin or swallow any of such liquid by mistake, immediately wash the contacted areas and consult a medical doctor.
9. Tampering with the live parts and devices, regardless of whether the machine is powered, is prohibited.
10. Repairing, reforming and adjustment works must only be done by appropriately trained technicians or specially skilled personnel.
11. General maintenance and inspection works have to be done by appropriately trained personnel.
12. Repair and maintenance works of electrical components shall be conducted by qualified electric technicians or under the audit and guidance of specially skilled personnel. Whenever you find a failure of any of electrical components, immediately stop the machine.
13. Periodically clean the machine throughout the period of use.
14. Grounding the machine is always necessary for the normal operation of the machine. The machine has to be operated in an environment that is free from strong noise sources such as high-frequency welder.
15. An appropriate power plug has to be attached to the machine by electric technicians. Power plug has to be connected to grounded receptacle.
16. Remodel or modify the machine in accordance with the safety rules/standards while taking all the effective safety measures. We assume no responsibility for damage caused by reforming or modification of the machine.
17. The machine is only allowed to be used for the purpose intended. Other uses are not allowed.
18. Warning hints are marked with the two shown symbols.



Danger of injury to operator or service staff



Items requiring special attention

# 安全操作事项 FOR SAFE OPERATION



1. 为避免触电, 请不要打开电机的电箱盖, 也不要触摸电箱内部部件。
- 1.To avoid electrical shock hazards, neither open the cover of the electrical box for the motor nor touch the components mounted inside the electrical box.



1. 为避免人身伤害,移动防护罩、护手挡或安全装置时, 请不要开动机器。
  2. 为尽可能避免机器运转造成的人身伤害,手指、头部和衣服应远离上轮, 上轮周围不要放置任何物品。
  3. 为避免人身伤害,当您打开电源开关或操作机器时, 切勿将手放在机针下方。
  4. 为避免人身伤害,机器运转时, 切勿将手放入挑线杆防护罩内。
  5. 旋梭运转时, 勿将手指放在旋梭附近。另外, 换梭芯时, 请关掉机器电源开关。
  6. 为尽可能避免人身伤害,当翘起或抬起机头时, 勿将手指放入机器内部。
  7. 为尽可能避免机器的突然启动所造成的事故, 抬起机头时, 请关掉机器的电源。
  8. 机器配有电机, 机器未运转时, 电机无噪音; 为避免机器的突然启动所造成的事故, 请关掉机器的电源开关。
  9. 为尽可能避免触电或电器组件受损, 在插上或拔下插头之前, 请关掉电源开关。
1. To avoid personal injury, never operate the machine with any of the belt cover, finger guard of safety devices removed.
  2. To prevent possible personal injuries caused by being caught in the machine. Keep your fingers, head and clothes away from the handwheel, cover and the motor while the machine is in operation. In addition, place nothing around them.
  3. To avoid personal injury, never put your hand under the needle when you turn ON the power switch or operate the machine.
  4. To avoid personal injury, never put your fingers into the thread take-up cover while the machine is in operation.
  5. The hook rotates at a high speed while the machine is in operation. To prevent possible injury to hands, be sure to keep your hands away from the vicinity of the hook during operation. In addition, be sure to turn OFF the power to the machine when replacing the bobbin.
  6. To avoid possible personal injuries, be careful not to allow your fingers in the machine when tilting/raising the machine head.
  7. To avoid possible accidents because of abrupt start of the machine, turn OFF the power to the machine when tilting the machine head.
  8. If your machine is equipped with a serve-motor, the motor does not produce noise while the machine is at rest. To avoid possible accidents due to abrupt start of the machine, be sure to turn OFF the power to the machine.
  9. To prevent possible accidents because of electric shock or damaged electrical component(s), turn OFF the power switch in prior to the connection /disconnection of the power plug.

# 开机前的注意事项 Precautions Prior to Startup

1. 机头装箱前为了防止机件生锈,在部分均涂有较厚的防锈油脂,同时机头装箱后,还可能在较长的贮藏和长途运输阶段造成油脂硬化和在机器表面积聚灰尘,所以必须将表面的油脂和灰尘用汽油和洁净的软布擦拭干净。

2. 机器出厂时,虽经过周密的检查和试验,但在长途运输中也可能受到强烈的震动使机件松动或歪曲所以应该做一次周密的检查,并用手转动上轮,看机件之间有无转动困难、碰撞现象或其它不均匀的阻力,不正常的声响,如有应作适当的调整,机器状态正常后才可正式试车。

3. 油箱内机油液面高度没有在正常范围内绝不能开车。

4. 机器运转时,上轮转向应该是逆时针方向(从上轮外侧面看)。

5. 确认电控铭牌上所标电压及相位是否正确。

6. 生产日期见合格证。

1.The machine head is coated with a thick layer of rust-prevention grease before encasement , and the encased machine head may possibly be subjected to grease hardening and dust buildup on the machine surface in process of long storage and long-haul traffic; there fore , take care to remove the grease and dust from the surface using soft cloth and gasoline.

2.Though the machine was inspected and tested with care before factory leaving, it might be affected by violent vibration resulting in looseness or distortion of the machine parts; therefore the operator shall thoroughly check the machine, turn the upper wheel by hand and check it for difficulty in free rotation, slight impact, and other uneven resisting force or abnormal noises, and make appropriate adjustment if any to restore the machine state before formal trial run.

3.Never start up the machine if the oil liquid level in the oil box falls outside the normal range.

4.The upper wheel shall rotate counterclockwise (when it is viewed from the lateral surface of the upper wheel) when the machine is operating.

5.Check whether the voltage and phases indicated on the electric-control data plate are correct.

6.The date of manufacture is indicated on the certificate of conformity.

## 使用注意事项 Precautions for Use

1. 当接通电源或机器运转时，请勿将手与机针接触。
2. 机器运转时，请勿将手指伸入挑线杆防护罩内。
3. 操作者用手送料时，请勿将手指伸入护针架。
4. 机头翻动及拆手盖时，一定要切断电源。
5. 操作者离开机器时，必须切断电源。
6. 机器运转时，绝不允许头或手以及任何东西靠近上轮、绕线器。
7. 只有在停机时，才能装卸防护罩或其它保护装置。
8. 不能用香蕉水等油漆稀释剂擦拭机头表面。

1. Never touch the needle by hand when the machine is powered on or while it is operating.
2. Never put your finger into the protection cover of take-up lever during operation of the machine.
3. The operator must not put his finger into the needle guard bracket when he feeds the sewing materials by hand.
4. Operator must trim off the electricity supply before he turns over the machine head or removes the hand cover.
5. The operator must trim off the electricity supply before he gets away from the machine.
6. Prohibit the head, hands and anything to approach the upper wheel and bobbinwinder while the machine is operating.
7. Never remove or mount the protection cover or other protection devices before the machine is stopped.
8. Never wipe up the surface of machine head using paint thinner such as acetone.

# 供油

## Oil supply



油量是使油面处于H线和L线之间为好。当油面低于L线时，就要及时补充机油。

After filling the oil pan , the top of the indicator should between (H) and (L) lines.  
Add oil , when the oil level indicator reaches or goes below (L).

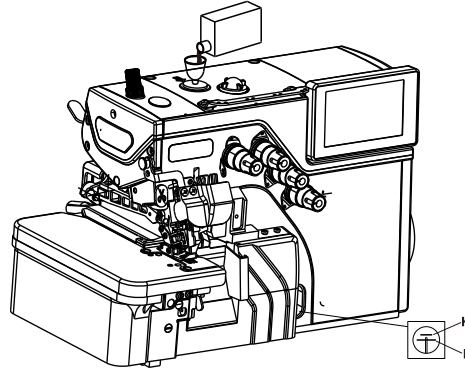

手动给油是在缝纫机最初开始使用时，或相当一段时间没使用时，请供给2-3滴油。

Apply 2 or 3 drops of oil by hand when the machine is used for the first time or has been left unused for some time.

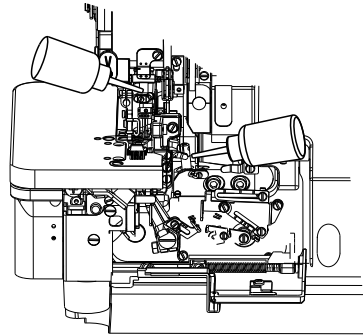

为防止断线，尽早给HR装置供油。

注：关于购买硅油，请咨询代理商或与公司营业部联系。

Fill the HR device with oil before it is too low in order to prevent needle breakage and fabric damage.

Note : Use Pegasus recommended silicon oil .  
(union carbide corporation)

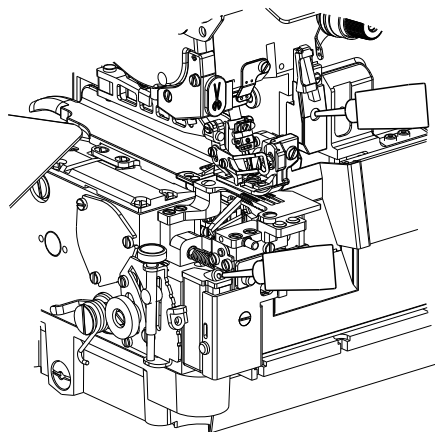

## 线状态的调整 Adjusting the thread tension

线的张力状态调节，请用夹线器组件来进行调节。

Please adjust the tension state of the wire using the wire clamp component .

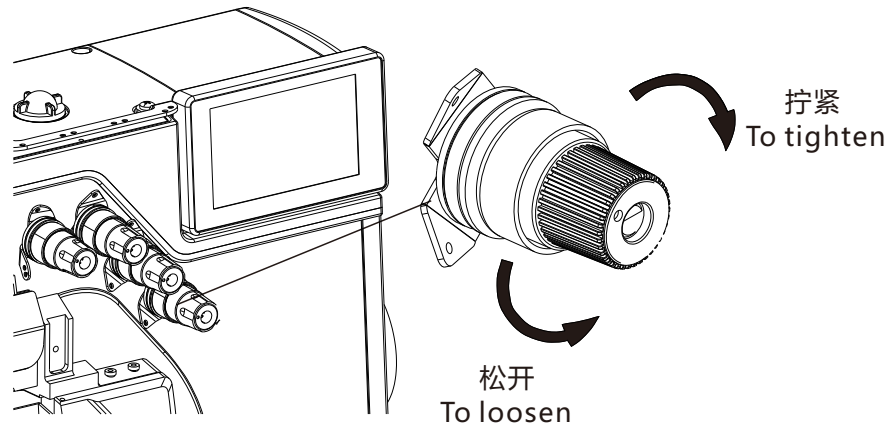

## 更换机油 Replacing the oil

机油的更换，请在使用开始1个月后更换一次，然后每6个月更换一次。

供油详情参见第6页。

Replacing the oil one month after the first use and every six months thereafter .(See P6)

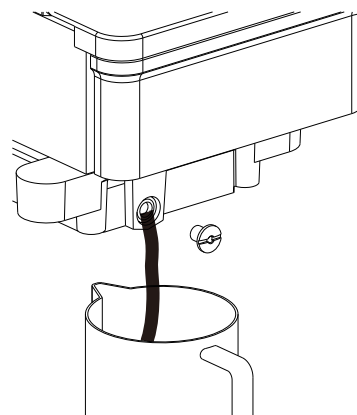

# 穿线 Threading

1. 打开压脚、缝台、前盖板三处。

Open three covers.

Presser、Cloth Plate、Side Cover

2. 把机上原有的线与缝纫用线绑结在一起。

Knot the preset thread and the thread being used together to thread the machine.

3. 将线拉到针眼前，剪掉线头再次穿好针线。

Trim the knots off neatly before passing through the eye of the needle to rethread.

4. 线拉出接头后，用剪刀剪齐接头。

Trim the knots off neatly after passing through the eye of the looper.

5. 若机上原来没有线，请参照穿线图正确进行穿线。

Make sure the machine is threaded correctly by referring to the threading diagram.

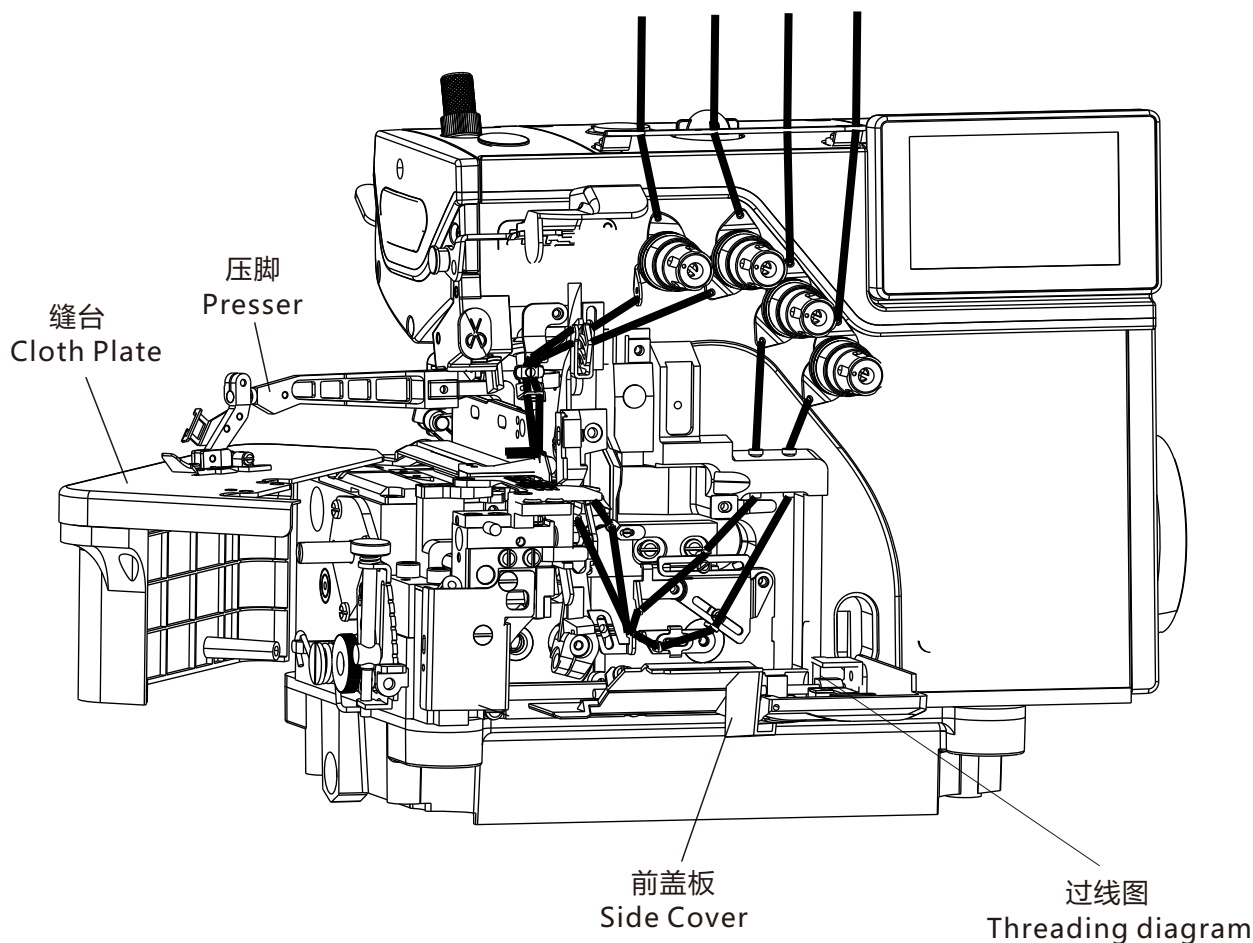

# 压脚的压力调节

## Adjusting the presser foot pressure

压脚的调节，松动螺母 ①，调节螺母 ②，在送布得到稳定状态下尽早可能使用较弱的压力为好。

Loosen adjusting nut ① and turn adjusting nut ② to adjust the presser foot. It should be as light as possible. yet be sufficient to obtain the proper stitch formation.

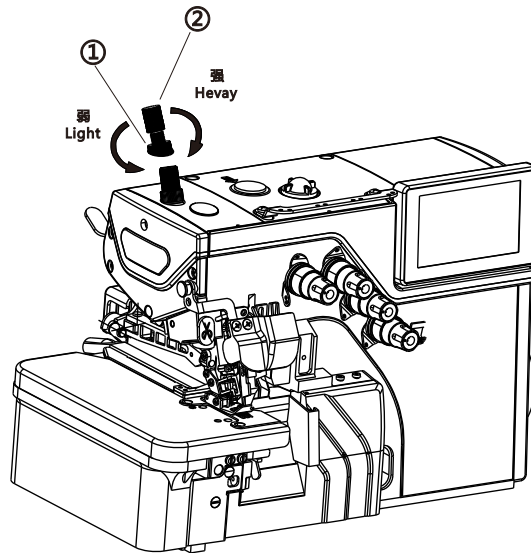

# 差动比的调节

## Adjusting the diff

差动比的调节松开螺母③调节螺母④

Loosen the adjusting nut ③ and turn the adjusting nut ④ to adjust the differential feed ratio.

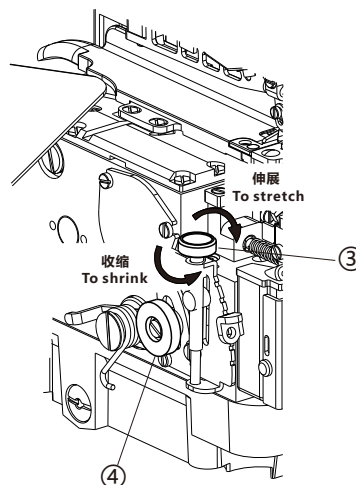

## 换针

# Replacing the needle

准确辨认针的前后，请将针凹向后方，即背向操作者进行安装。  
针要牢固的插到孔的最深处。

Check the needle carefully to see that the scarf is turned to the rear of the machine .

Insert the needle to the proper depth , and fasten securely .

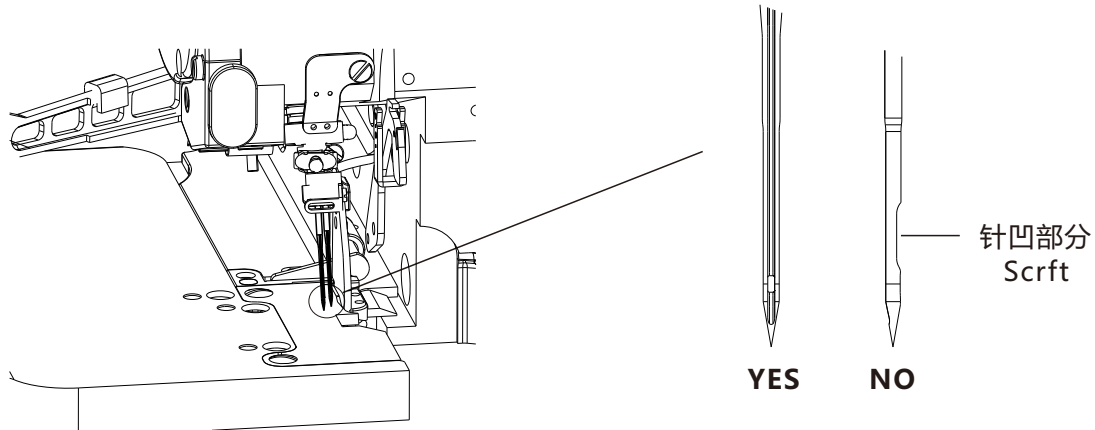

## 缝纫机的清扫

# Cleaning the machine

缝纫机的清扫，以针板槽和送布牙周围为主。

Mainly the slots of the needle plate and the feed rows should be cleaned .

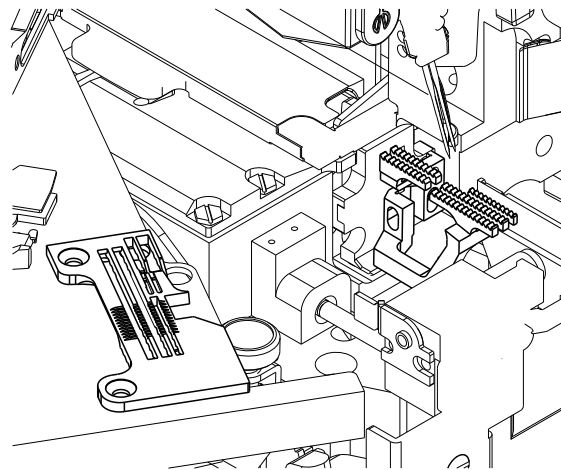

# 下刀片的更换

## Replacing the lower knife

卸下刀片  
To remove the lower knife

松开螺丝  
Loosen the screw

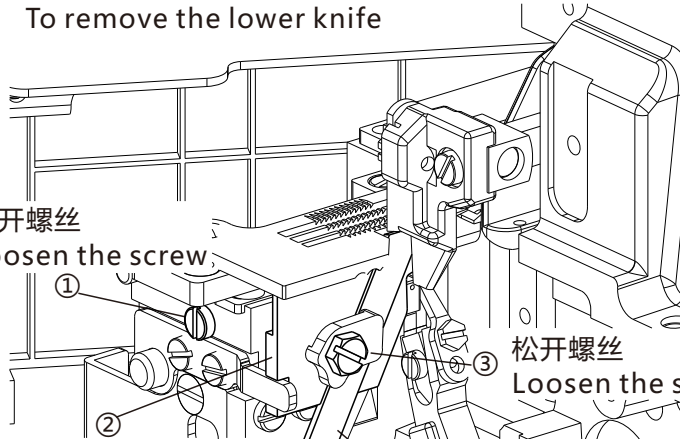

把下刀架推向左边，  
用螺丝①暂时固定  
Temporarily screw ① after  
sliding the lower knife holder  
to the left.

松开螺丝  
Loosen the screw

取下刀片  
Remove the lower knife

转动手轮将上刀移动对准  
如右图所示位置  
Turn the handwheel as the  
drawing on the right figure

安装下刀片  
To replace the lower knife

拧紧螺丝  
Tighten the screw

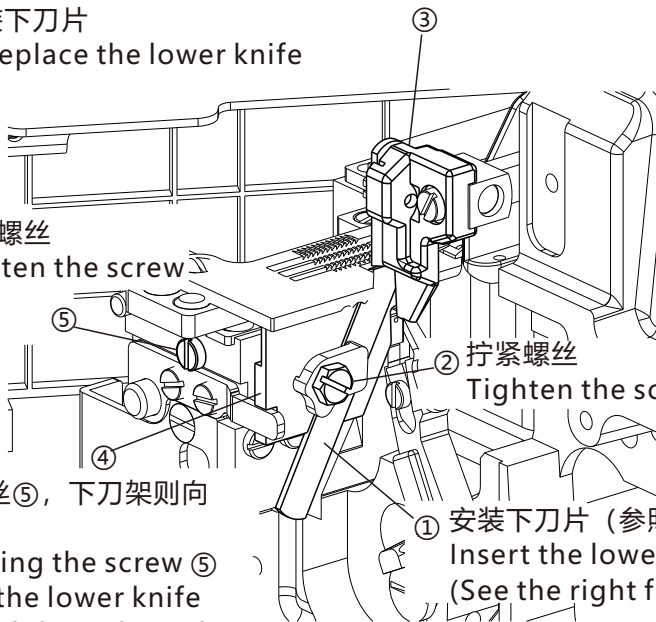

松开螺丝⑤，下刀架则向  
右移动。  
Loosening the screw ⑤  
makes the lower knife  
holder slide to the right.

拧紧螺丝  
Tighten the screw

① 安装下刀片 (参照右图)  
Insert the lower knife  
(See the right figure)

上刀片  
Upper knife

下刀刃B  
Cutting edge of  
the lower knife B

针板表面A  
Top surface of  
the needle A  
plate

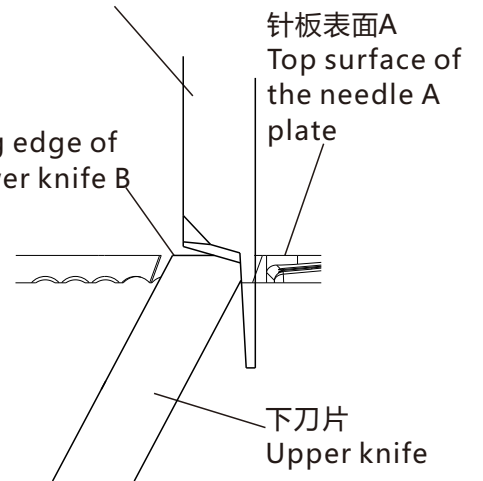

下刀片  
Upper knife

使针板表面A与下刀片刃B处于相  
同水平位置  
Level of A = level of B

装好下刀片后进行剪线，确认剪切状况  
Check cutting action of knife