

WS-25

Washer-extractor Controller

Factory Manual

[For Engineer]

Please read the manual carefully before installation and operation !









Software version

X1.LD009A.X16.002-11 V100B8

X1.LL005A.X16.003-1/X1.LL005A.X16.003-10



Rights Reversed, Pirate Punished

【Safety Precautions】



Installation	 Dangerous	<ul style="list-style-type: none"> ● Please fix the controller to avoid vibrate drops. ● Please install the controller in the metal or not inflammable board.
	 Caution	<ul style="list-style-type: none"> ● Please guarantee electric cabinet temperature among -10°C ~$+50^{\circ}\text{C}$, adding the ventilating fan when necessary. ● Do not expose in the sunlight, strong airflow and mist ● Do not expose in corrosive and pollution gas, such as sulfide gas, salt mist.
Wiring	 Dangerous	<ul style="list-style-type: none"> ● Please confirm the power supply is OFF. ● Let the professional worker to wiring ● Signal without source input, please do not connect with power supply, ● Please increase the system protection, avoids the controller invalid and cause dangerous.
	 Caution	<ul style="list-style-type: none"> ● Please observe the strong and weak electricity separation principle. ● Please use the conforms to the technical standard wire ● Please select the parallel method,
Parameter	 Caution	<ul style="list-style-type: none"> ● According to the machine configuration, set the related parameter, guarantees the machine running.
Run	 Dangerous	<ul style="list-style-type: none"> ● After confirming the wiring correctly, then power on. ● Guarantee environmental condition and the power supply voltage is in permit condition, only in this way can start the machine. ● When running, please do not inspect the signal. ● When running, please do not change the parameter setting. ● When running, please do not approach the machine.
Maintenance, inspection	 Caution	<ul style="list-style-type: none"> ● The user has any repair needs, please contact with manufacturer, do not intend to repair it by yourself. ● Please do not pull, twist the power line and communication line. ● Please do not touch the controller device directly.
	 Dangerous	
Others	 Dangerous	<ul style="list-style-type: none"> ● Please be careful when simulating and adjusting the controller on the desk. Presence of high voltage could cause electrical hazard and injury.

Symbol explanation

Please familiarize yourself with the following standard warning symbols. They are used throughout this manual to alert you the possible hazards. Anyone installing, operating and servicing this controller must understand these symbols and follow all the safety rules in this manual.

 Dangerous	It will cause the dangerous situation, possibly will cause the personal injury or death when error using.
 Caution	It will cause the dangerous situation, possibly will lead to personal injury or death, property damage and economic loss when error using.

【Responsibility statement】

 Caution  Dangerous
<ul style="list-style-type: none">● In case of any consequence which corrupts or bugs the controller's software, PUNP reserves the right to repair the bug, but does not have the responsibility to undertake any compensation.● In case of the controller's hardware error, PUNP has the right to repair the flaw, but does not have the duty to undertake any responsibility.● Because of improper use, PUNP does not have the duty to undertake any responsibility.● PUNP has the right to go to the end user's service, but does not have the duty.

NOTE : This manual is subject to change without separate notification.

Content

1 GENERAL	1
2 INSTALLATION	2
2.1 Dimension.....	2
2.1.1 Front panel	2
2.1.2 I/O control Board	3
2.3 Electric Connection	4
2.4 Controller Connection Schematic Drawing.....	5
2.5 Inverter Parameter Setup	6
2.5.1 Digital Input	6
3 BUTTONS INTRODUCTION	8
4 RUNNING	10
4.1 Startup	10
4.2 Manual Running Mode	10
4.2.1 Start Manual Running.....	10
4.2.2 Change Time, temperature, level	10
4.2.3 Stop Machine	10
4.3 Automatic Running.....	10
4.3.1 Start Automatic Running.....	10
4.3.2 Automatic Running.....	10
4.3.3 Pause and Continue	10
4.3.4 Manual Operate.....	10
4.3.5 Advance Step	10
4.3.6 Ending Automatic Running.....	10
5 PROGRAMMING	12
5.1 Create New Program	12
5.1.1 Select and enter	12
5.1.2 Edit.....	12
5.1.3 Exit and save	12
6 PARAMETER	13
6.1 Parameter initialization.....	13
6.2 Machine parameter setup.....	13
6.3 PUNP inverter setup	18
7 ALARM	21
7.1 Alarm Reset.....	21
7.2 Alarm Information and Obviation	21
7.2.1 Faults of PUNP inverter	22
7.2.2 Alarms of PUNP inverter.....	24

1 GENERAL

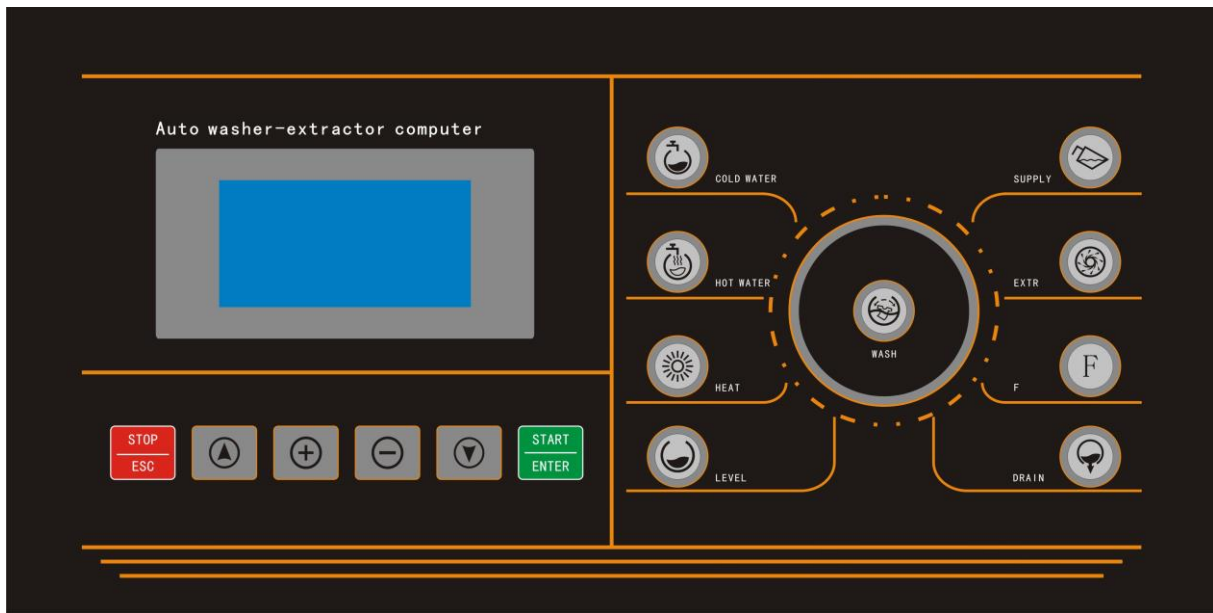

This schematic photo is just for reference !

WS-25 controller is specially designed for the control of the automatic washer extractor. It features stability and reliability in operation.

WS-25 controller has very convenient human-machine interaction interface with liquid crystal display to show state of operation of the machine including temperatures at Led display and thus helps monitoring effect. A reliably sealed, water and dust proof key panel is adopt which contains light touch keys with over one million times working life.

The controller provides both automatic and manual working modes. Under manual mode, all keys are properly interlocked to avoid possible misoperation. For automatic mode, 30 different cycles can be programmed and upon a single touch of the [Start] key, the machine will run automatically to the end of the selected cycle.

WS-25 controller also provides washer extractor with the following characteristics:

- ◆ Relays are used as output components to control directly the driving components. This omission of intermediate relays conduces to less errors and easier maintenance and trouble shooting.
- ◆ Timer operation selected under manual mode.
- ◆ During automatic operation programmed time duration of an on-going step could be modified manually without stopping the operation.
- ◆ During operation actual temperatures and set temperatures can be called to display at will.
- ◆ Maximum extraction time limit were devised to prevent damage to textiles and machine parts due to excessive extraction.
- ◆ Deal with unbalance under extracting status intelligently
- ◆ Ajust the level at your option.
- ◆ Various parameters integrated in the computer, which can be set up by manufacturer before Exworks.

2 Installation

2.1 Dimension

2.1.1 Front panel

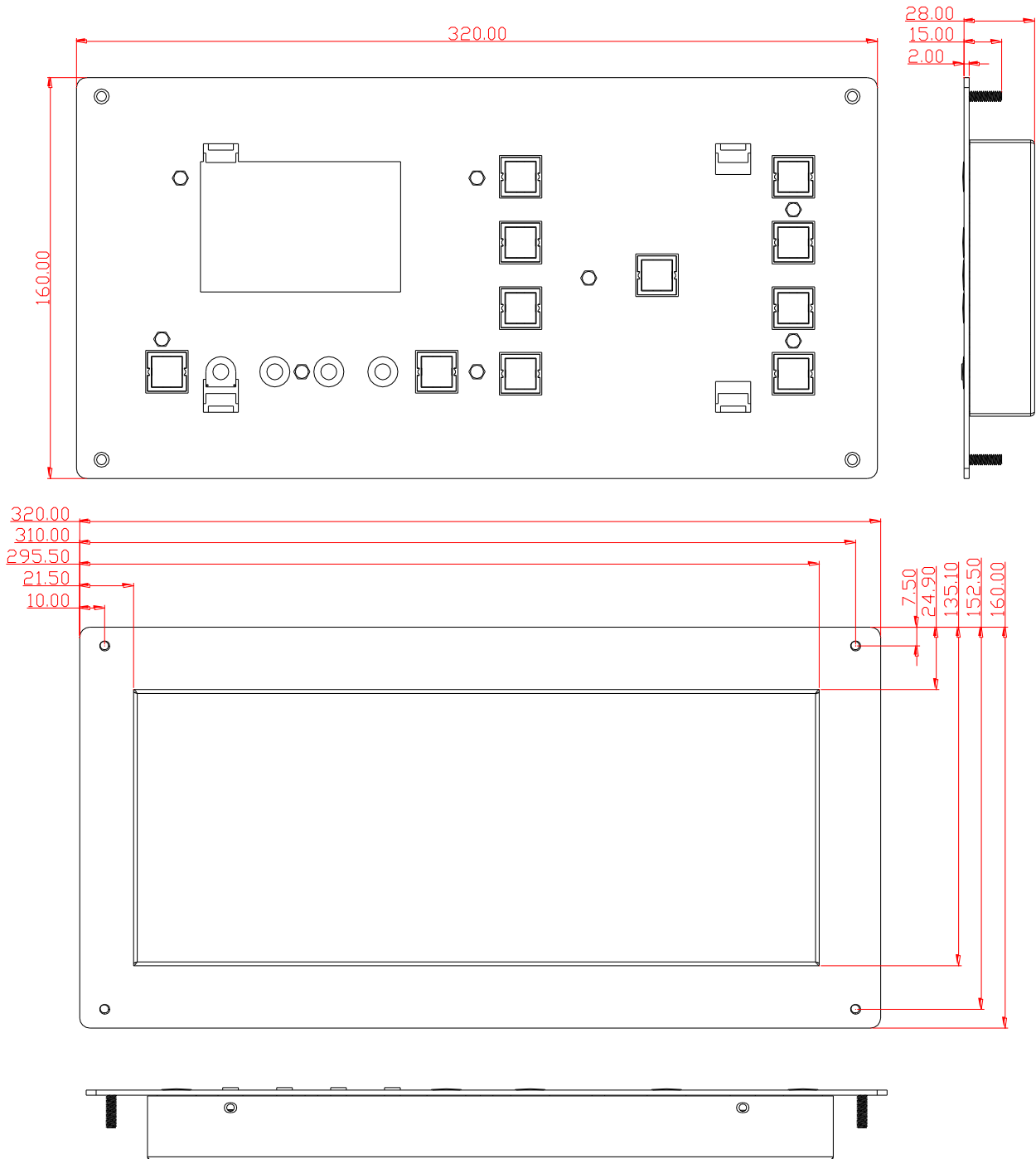

2.1.2 I/O control Board

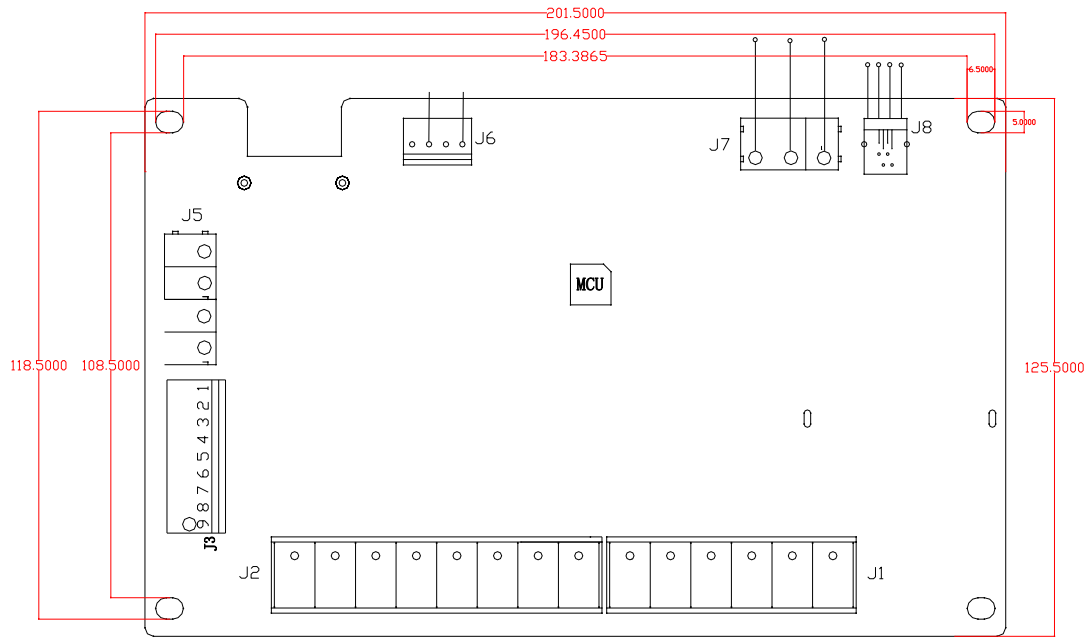

2.3 Electric Connection

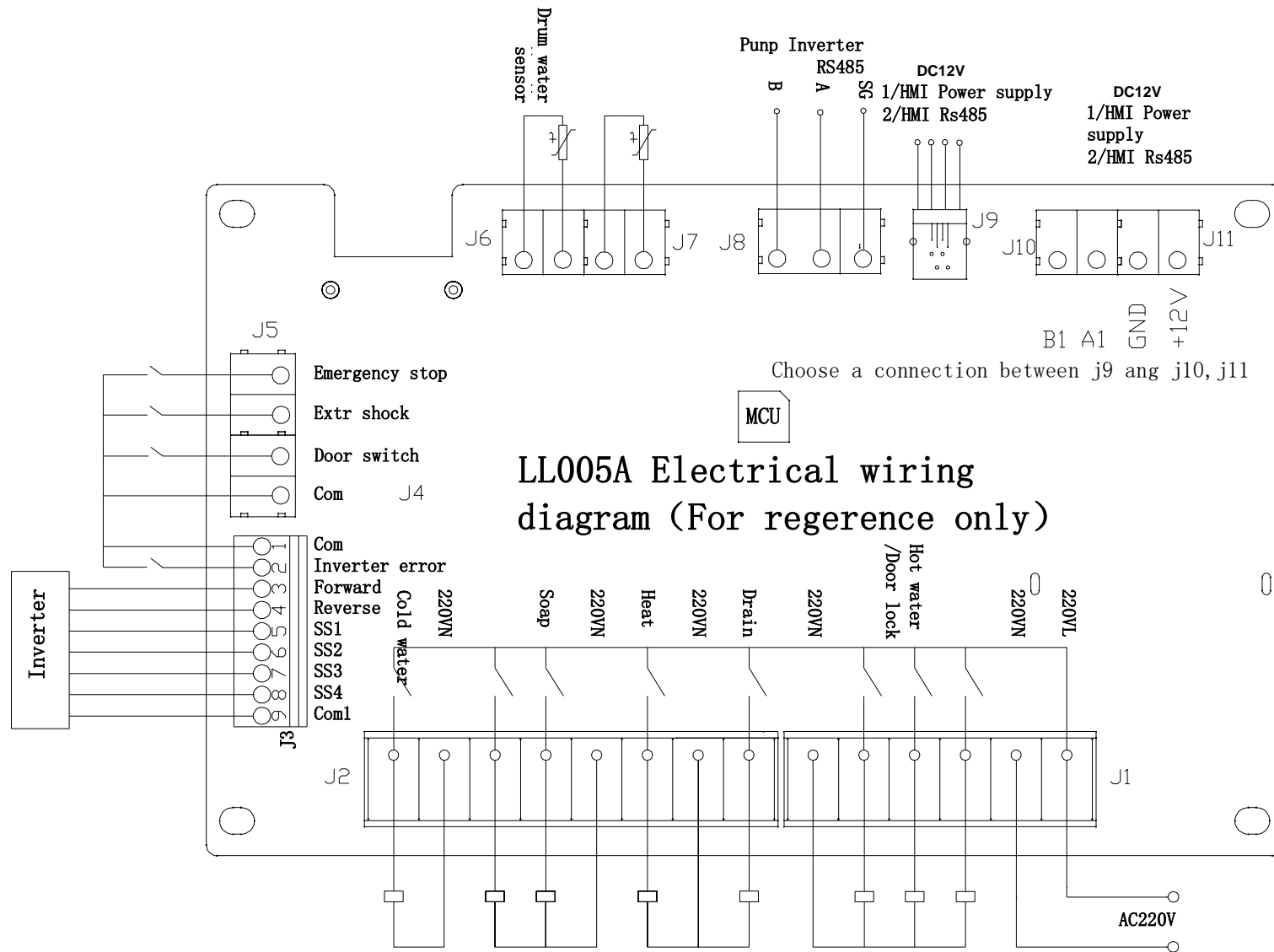

1、NOTE: Electric connection diagram is just for reference.

2.4 Controller Connection Schematic Drawing

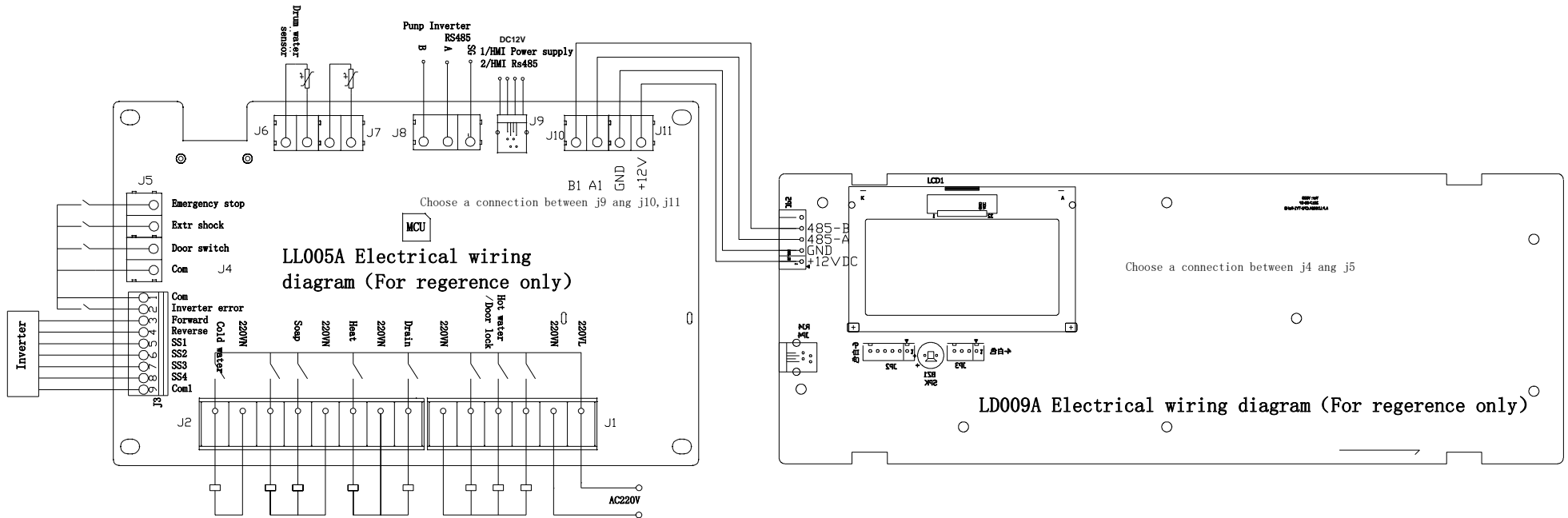

2.5 Inverter Parameter Setup

There are two ways to controller inverter:

2.5.1 Digital Input

◆ Digital input List

The controller parameter “Base number of inverter” is 0:

	Wash Forward	Wash Reverse	Extract Forward	Extract Balance	Extract Middle	Extract High 1	Extract High 2	Extract High 3	Extract High 4
SS1	0	0	0	1	0	1	0	1	0
SS2	0	0	0	0	1	1	0	0	1
SS3	0	0	0	0	0	0	1	1	1
Second Speed	0	0	0	0	1	1	1	1	1
Forward	1	0	1	1	1	1	1	1	1
Reverse	0	1	0	0	0	0	0	0	0

The controller parameter “Base number of inverter” is 1:

	Wash Forward	Wash Reverse	Extract Forward	Extract Balance	Extract Middle	Extract High 1	Extract High 2	Extract High 3	Extract High 4
SS1	1	1	1	0	1	0	1	0	1
SS2	0	0	0	1	1	0	0	1	1
SS3	0	0	0	0	0	1	1	1	1
Second Speed	0	0	0	0	1	1	1	1	1
Forward	1	0	1	1	1	1	1	1	1
Reverse	0	1	0	0	0	0	0	0	0

When the parameter “WashDiffSpeed” is set to yes,the washing uses different speed.

◆ Digital input List

The controller parameter “Base number of inverter” is 0:

	Wash LowSpeed	Wash Midspeed	Wash highspeed	Extract Forward	Extract Balance	Extract Middle	Extract High 1	Extract High 2	Extract High 3
Forward	1/0	1/0	1/0	1	1	1	1	1	1
Reverse	1/0	1/0	1/0	0	0	0	0	0	0
SS1	0	1	0	0	1	0	1	0	1
SS2	0	0	1	0	1	0	0	1	1
SS3	0	0	0	0	0	1	1	1	1
Second Speed	0	0	0	0	0	1	1	1	1

The controller parameter “Base number of inverter” is 1:

	Wash LowSpeed	Wash Midspeed	Wash highspeed	Extract Forward	Extract Balance	Extract Middle	Extract High 1	Extract High 2
Forward	1/0	1/0	1/0	1	1	1	1	1
Reverse	1/0	1/0	1/0	0	0	0	0	0
SS1	1	0	1	1	0	1	0	1
SS2	0	1	1	0	0	0	1	1
SS3	0	0	0	0	1	1	1	1
Second Speed	0	0	0	0	0	1	1	1

Note:when inverter type is punp inverter,the controller SS4 can't connect with inverter.

◆ The controller and inverter parameter

The controller parameter:

Group	Item	Value
P6:Inverter setup	1:Inverter type	Standard inverter
P6:Inverter setup	2:Inverter Control.	Relay
P6:Inverter setup	3:Base number of invert.	0~1

The inverter parameter:











LG-IG5/ LG-IS5:



Item	Value (LCD)	Value (7 -Segment)
DRV-03: Drive mode	FX/RX-1	1
DRV-00: Cmd. freq	Need	Need
DRV-05~DRV-07: Step freq-1~3	Need	Need
I/O-21~I/O-24: Step freq-4~7	Need	Need
I/O-12: P1 define	Speed-L	0
I/O-13: P1 define	Speed-M	1
I/O-14: P1 define	Speed-H	2

Delta B:

Item	Value
02-01 Cmd	01: Digital Input With STOP 02: Digital Input Without STOP
04-04~04-07 MI1~MI4	01~04: Speed
05-00~05-14 Step freq	Need

3 Buttons introduction

Icon	Function
	<p>[wash] button Press this button to switch among Standard washing ways and stopping washing.</p>
	<p>[Cold Water] button Switch between starting adding cold water and stopping adding cold water by pressing this button when the actual level is lower than the set level.</p>
	<p>[Hot water] button Switch between starting adding hot water and stopping adding hot water by pressing this button when the actual level is lower than the setting level.</p>
	<p>[Heat] button Switch between starting heating and stopping heating by pressing this button when the actual temperature is lower than the set temperature and the actual level is higher than the value of "Safety level of heat" parameter.</p>
	<p>[Drain] button Switch between starting drain and stopping drain by pressing this button.</p>
	<p>[Extract] button Switch between starting medium extract and stopping medium extract by pressing this button.</p>
	<p>[Supply] button Under "manual" mode, the supply will work for 30 seconds by pressing this button and you also can stop the supply during supply working by pressing this button.</p>
	<p>[Level] button Switch the level among low level, medium level, high level and calibration level by pressing this button.</p>
	<p>[Start] button Under "Lock" status, press this button to start executing the selected program</p>
	<p>[Stop] button Under "manual" Mode, press this button to stop current operation; Under "auto" Mode, press this button to stop current running program. Under "idle" Mode and use doorlock, press this button to control door lock.</p>
	<p>[F] button Function output.</p>

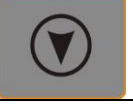
	[ADD] button Midify parameter in parameter setup
	[SUB] button Midify parameter in parameter setup
	[UP] button Slect item
	[DOWN] button Slect item

4 Running

4.1 Startup

After power is on, the LCD shows the startup interface for 10 seconds..



4.2 Manual Running Mode

4.2.1 Start Manual Running

Power on and close the door, it will enter into “Closed status”. Lock the door by pressing **[stop]** button. Enter into “Manual mode” by pressing any of the following buttons (**[Wash]**, **[Cold Water]**, **[Hot Water]**, **[Heat]**, **[Drain]**, **[Extract]**, **[Supply]**)

4.2.2 Change Time, temperature, level

Select the setting items between time, temperature or level by pressing **[↑]** **[↓]** button and set the value by pressing **[+]** and **[-]** buttons under manual mode.

Switch the level among low level, medium level, high level and calibration level by pressing **[Level]** button.

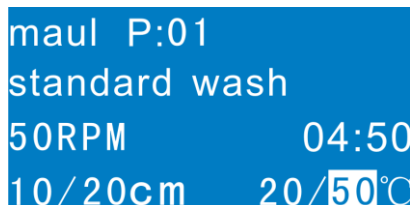

4.2.3 Stop Machine

Press **[Stop]** button to stop all the actions running, and return to “Locked status”.

4.3 Automatic Running

4.3.1 Start Automatic Running

On Program select interface, choose your desired program by pressing **[↑]** and **[↓]** buttons under “locked” status, and then press **[Start]** button to start the program.

On automatic running interface, shows the information, time, water level, water temperature and steps. User also can change time, speed, water level, water temperature manually.

4.3.2 Automatic Running

When the machine is running, user can pause, continue, or stop the machine, can change time, speed, water level, water temperature manually, and also can advance to a new step.

On pause status, the controller clue user “Pause run,press <Start>”.

4.3.3 Pause and Continue

When the machine is running, user press **[Start]** button to stop the machine. On pause status all the actions is stopped, the count down time is also stopped. Press **[Start]** button to continue running.

Note:

1. Extract step can not be paused.

4.3.4 Manual Operate

When the machine is running, user can change time, speed, water level, water temperature, actions manually.

4.3.5 Advance Step

When the machine is running, user can skip to the next or above step by pressing **[+]** or **[-]** button.

4.3.6 Ending Automatic Running

After complete the last step or press **[Stop]** button, the controller becomes ending status. The controller beeps on to clue user, you can stop the buzzer by pressing **[Start]** button during this beeping time. User also can lock or unlock the door, and run this program again immediately.

5 Programming

There are 30 programs on the controller.

5.1 Create New Program

5.1.1 Select and enter

Select your desired program under “Idle” status, press [↑] [↓] button, it will enter into “program” status.

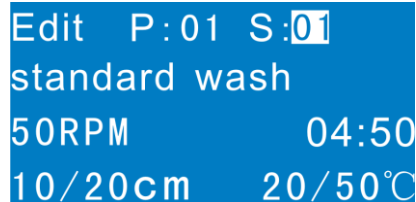

The image shows a blue LCD screen with white text. The text is arranged in four lines: 'Edit P:01 S:01', 'standard wash', '50RPM 04:50', and '10/20cm 20/50°C'. The 'S:01' has a small cursor box around the '1'. The '04:50' has a small cursor box around the '5'. The '20/50°C' has a small cursor box around the '5'.

5.1.2 Edit

Select your desired step by pressing [+] and -] buttons to select your desired step.

Press [Start] button for 3 seconds to delete program completely.

5.1.3 Exit and save

If Press the [Stop] button 3seconds under “program” status, LCD displays the information to ask the user whether save the program . Save the program by pressing [Enter] button. Exit without saving and return to main working interface by pressing [ESC] button.

6 Parameter

Note: All parameters have already been configured for the machines in factory. Don't intend to modify any parameter without any special requirement. Some modification will lead to abnormal work.

In "count down" interface. Press < ↑ > < ↓ >. Enter the parameter interface:



- Press [↑] or [↓] button to select setting item and press [ENTER] button to enter into the selected item.
- Select the sub-item by pressing [↑] or [↓] button. Press [ADD] or [SUB] button to set the value. After modification, press [CANCEL] button to exit and then press and hold [CANCEL] button for 3 seconds to reserve the modified value and exit to the idle page.
- Default factory password is : [COLD WATER] [HOT WATER] [HEAT] [LEVEL] [SOAP] [EXTR] [F] [DRAIN] . factory password can be used to set all the items of parameters.
- Default user password is: [COLD WATER] [HOT WATER] [HEAT] [LEVEL] [COLD WATER] [HOT WATER] [HEAT] [LEVEL]. User password can only be used to set the items with "end user" level.

6.1 Parameter initialization

On the top menu Of parameter setup interface, press [↑] or [↓] button to select "1:Set to defaults" and press [ENTER] button to enter into this item.

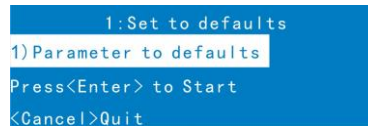

Press [↑] or [↓] button to select "1: Parameter to defaults" and press [ENTER] button to reset all the parameters to default value.

Press [↑] or [↓] button to select "2: Program to defaults" and press [ENTER] button to reset all the programs to default value.

6.2 Machine parameter setup

On the top menu Of parameter setup interface, press [↑] or [↓] button to select "2:Machine setup" and press [ENTER] button to enter into this item.

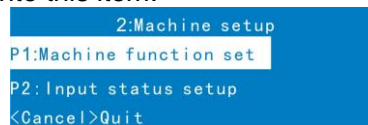

Group	Items	Default	Range	Introduction	Level
1: Machine function set	1:Machine capacity	15KG	0~200KG		Factory
	2:Language	Chinese	Chinese, English,Russian, Spanish		End User
	3:Temperature units	Celsius	Celsius, Fahrenheit		End User
	4:Drain while door open	No	No,Yes	Open drain valve automatic after open the door for the safety of the operator.	Factory
	5:Drain valve status	N.C	N.C.,N.O.	Open: Drain valve is opened while draining. Close: Drain valve is closed while draining.	Factory
	6:Count time after heat	No	No,Yes	Wash time without heat time, must reach temperature.	End User
	7:Require lubrication	0	0~9999 times	When the times of run reaches this value, it will prompt information of adding lubrication under door open status. The times of run can be browsed and be cleared by pressing [Extract] button for 3 seconds from startup screen.	Factory
	8:Count time after fill	Yes	No,Yes	Wash time without fill time, must reach water level.	End User
	9:Use password	No	No,Yes		Factory
	10: Logo	Default	Default, Self-Defined		Factory
	11:ManIWhenAuto	Yes	No,Yes		End User
	12:StepWhenAuto	Yes	No,Yes		End User
	13:UseWashSensor	Yes	Yes,NO	Yes:Use washsensor	Factory
	14:WashDiffSpeed	NO	No,Yes	Yes:the washing uses different speed	Factory
	15:Unlock Delay	0 Sec	0~120 Sec	If the parameter is not 0,the function is enabled.After pressing the unlock,delay for a period of time	Factory
2: Input status setup	1:Inverter error	N.C	N.C.,N.O.	Open: Inverter error when input signal is invalid. Close: Inverter error when input signal is valid.	Factory
	2:Door closed	N.O	N.C.,N.O.	Open: Door closed when input signal is invalid. Close: Door closed when input signal is valid.	Factory
	3:Extract shock	N.C	N.C.,N.O.	Open: Extract shock when input signal is invalid. Close: Extract shock when input signal is valid.	Factory
	4:Emergency stop	N.C	N.C.,N.O.	Open: Emergency stop when input signal is invalid. Close: Emergency stop when input signal is valid.	Factory
3:Fill and level	1:Zero level	5cm	0~99cm	Set the relative zero level.	Factory
	2:Low level	28cm	0~Middle Level	Set the low level for manual or auto run.	End User

setup	3:Middle level	35cm	Low Level~High Level	Set the middle level for manual or auto run.	End User
	4:High level	41cm	Middle Level~Overbrim Level	Set the high level for manual or aut run.	End User
	5:Overbrim level	99cm	High Level~99cm	Set the overbrim level. Drain valve will open when water higher than the overbrim level.	End User
	6:Auto re-fill when low	No	No,Yes	Auto re-fill when level is lower than set value.	End User
	7:Level diff. of re-fill	4cm	0~99cm	Auto re-fill when difference between current and set is larger than level difference of re-fill.	End User
	8:Max time of fill	20 Min	0~255 Min	If level is also lower than set value in time, controller will alarm.	End User
	9:Safety level of hot	10cm	0~99cm	Auto fill cold water when level is lower than safety level while filling hot water.	End User
	10:Hot fill intellective	No	No,Yes	Fill hot water or cold water intellective to reach set temperature value.	End User
4:Heat and temp. setup	1:Min water temperature	0°C	0~Max Temperatrue	The min value of water set temperature.	End User
	2:Max water temperature	90°C	Min Temperatrue~99°C	The max value of water set temperature	End User
	3:Temperature of heat	70°C	Min Temperatrue~Max Temperatrue	The default value of temperature of heat	End User
	4:Auto re-heat when low	No	No,Yes	Auto re-heat when temperature is lower than set value.	End User
	5:Temp. diff. of re-heat	4°C	0~99°C	Auto re-heat when difference between current and set is larger than temperature difference of re-heat.	End User
	6:Max time of heat	60 Min	0~255 Min	If temperature is also lower than set value in time, controller will alarm.	End User
	7:Safety level of heat	10cm	0~100cm	Auto fill cold water when level is lower than safety level while heating.	End User
5:Soap setup	1:Stop filling	Yes	No,Yes	Stop fill cold water while soaping to avoid low water pressure.	End User
	2:Safety level	10cm	0~99cm	Auto fill water when level is lower than safety level while soaping.	End User
	3:Set time of soap	20 Sec	0~255 Sec	Default set time of soap	End User
6: Inverter setup	1:Inverter type	Gerenal	Gerenal、PUNP Inverter		Factory
	2:Inverter control.	Relay	Relay,RS485		Factory
	3:Coeff of freq and rev	0.2400	0.0001~0.9999	Coefficient of frequency and rev : Frequency = Rev * Coefficient.	Factory
	4:Base number of invert.	0	0~1	Base number of inverter while use input signal.	Factory
7:Wash setup	1:Minimum pause fwd/rev	5 Sec	1~255 Sec	Min time between forward and reverse to avoid motor overload.	Factory
	2:Standard wash run time	25 Sec	1~255 Sec	Standard wash run time, includes forward and reverse.	End User
	3:Stand. wash stop time	5 Sec	1~255 Sec	Standard wash stop time, includes forward and reverse.	End User

	4:Gentle wash run time	15 Sec	1~255 Sec	Gentle wash run time, includes forward and reverse.	End User
	5:Gentle wash stop time	5 Sec	1~255 Sec	Gentle wash stop time, includes forward and reverse.	End User
	6:Heavy wash run time	35 Sec	1~255 Sec	Heavy wash run time, includes forward and reverse.	End User
	7:Heavy wash stop time	5 Sec	0~255 Sec	Heavy wash stop time, includes forward and reverse. When "Heavy wash stop time" is set to "0", it becomes single wash.	End User
	8:Speed of normal wash	40 rpm	1~ Max speed of wash	Default speed of normal wash.	End User
	9:Max wash speed	60 rpm	1 ~ 100	Max speed of wash. Wash at max speed when the set value is larger than max speed.	Factory
	10: Speed of gentle wash	40 rpm	1~ Max speed of wash	Default speed of gentle wash.	End User
	11:Speed of single wash	40 rpm	1~ Max speed of wash	Default speed of single wash.	End User
8: Extract setup	1:High extract number	1	1~4	High extract number. There are four high extract most	Factory
	2:Level for balance	20cm	0~99cm	Auto fill to level at least before extract to avoid shock.	End User
	3:Balance drain level	10cm	0~99cm	If the level is higher than level at most after balance drain, controller will alarm.	End User
	4:Forward run time	10 Sec	1~255 Sec	Forward run time at beginning of extract.	End User
	5:Bala. with water time	25 Sec	1~255 Sec	Balance with water time at extract.	End User
	6:Bala. drain water time	70 Sec	1~255 Sec	Balance drain water time at extract.	End User
	7:Mid extract time	45 Sec	1~255 Sec	Time of mid extract.	End User
	8:High extract 1 time	60 Sec	1~255 Sec	Time of high extract 1.	End User
	9:High extract 2 time	60 Sec	1~255 Sec	Time of high extract 2.	End User
	10:High extract 3 time	60 Sec	1~255 Sec	Time of high extract 3.	End User
	11:Maximum extract time	5 Min	1~255 Min	Max time of extract at last phase.	End User
	12:Mid extr. delay time	40 Sec	10~255 Sec	Delay time from end of mid extract.	Factory
	13:High extr. delay time	60 Sec	20~255 Sec	Delay time from end of high extract.	Factory
	14:Re-extract times	3	0~20	Re-extract times when shock. If the times is larger than the set value, controller will alarm.	Factory
	15:Re-extract wash time	60 Sec	0~255 Sec	Wash time before re-extract to unroll the clothes.	End User
	16:Balance delay time	30 Sec	0~255 Sec	Delay time from end of balance.	End User
	17:Forward run speed	40rpm	1~ Balance speed	Forward run speed at beginning of extract.	Factory
	18:Balance speed	100rpm	Forward Speed~ Mid extract speed	Balance speed at extract.	End User

	19:Mid extract speed	300rpm	Balance Speed~Max Mid Extract Speed	Speed of mid extract.	End User
	20:High extract 1 speed	500rpm	Mid Extract Speed~Hi 2 Speed	Speed of high extract 1.	End User
	21:High extract 2 speed	700rpm	Hi 1 Speed~Hi 3 Speed	Speed of high extract 2.	End User
	22:High extract 3 speed	800rpm	Hi 2 Speed~Hi 4 Speed	Speed of high extract 3.	End User
	23:High extract 4 speed	900rpm	Hi 3 Speed~Max Hi Extract Speed	Speed of high extract 4.	End User
	24:Max speed of mid extr	400rpm	Mid extract speed ~600 rpm	Max speed of mid extract.	End User
	25:Max speed of hi extr	999rpm	High extract 1 speed ~999 rpm	Max speed of high extract.	Factory
10: Door lock setup	1:Use doorlock	NO	NO、YES	Yes:use doorlock function	Factory
	2: Safety temperature of unlock door	40°C	0~90°C	Can't unlock the door when temperature is higher than safety temperature.	End User
	3: Safety level of unlock door	0cm	0~99cm	Can't unlock the door when level is higher than safety level.	End User
	4: Door lock valve status	N.O.	N.C.,N.O.	Open: Door lock valve is opened while locked. Close: Door lock valve is closed while locked.	Factory
	5: Door lock type	Series	Series, Pulsed	Door lock type : Series and Pulsed.	Factory
	6: Lock action time with pulsed	10 Sec	0~99 Sec	Lock action time with pulsed.	Factory

6.3 PUNP inverter setup

On the top menu Of parameter setup interface, press [↑] or [↓] button to select “3: PUNP inverter setup” and press [ENTER] button to enter into this item.



Note:

Parameter 6.1 “Inverter type” should set as “PUNP Inverter” and 6.1 “Invertercontrol mode” should set as “Rs485”.

You can shift to other parameters by pressing [ENTER] button. The selected item will be displayed with a frame and highlight.

Group	Items	Default	Range	Introduction
1:Inv. initialization	1:Inv. para. initialize	/	/	
	2:Inv. para. upload	/	/	
	3:Inv. para. donwload	/	/	
	4:Inv. para. compare	/	/	
2: Inv. software info	1:Inv. rated capacity	/	/	Only read
	2:Software version	/	/	
3: Freq, accel/decel	1:Max. frequency	150.00Hz	“Upper-limit frequency” ~650.00Hz	
	2:Upper-limit frequency	150.00Hz	“Lower-limit frequency” ~ “Upper-limit frequency”	
	3:Lower-limit frequency	0.00Hz	0.00~ “Upper-limit frequency”	
	4:The corner freq.	11.00Hz	0~650.00Hz	
	5:Wash acceleration time	30.0s	1.0~3600.0s	
	6:Wash deceleration time	30.0s	1.0~3600.0s	
	7:Extract accel. time	30.0s	1.0~3600.0s	
	8:Extract decel. time	30.0s	1.0~3600.0s	
4:Start and stop setup	1:Starting frequency	2.50Hz	0.00~60.00Hz	
	2:Stop mode	Coast stop	Slowdown stop、Coast stop	
	3:DC brake freq(at stop)	2.5Hz	0.00~60.00Hz	
5: V/F ctrl parameters	1:V/F curve	Linear V/F curve	Self-defined、Linear V/F curve	
	2:Torque boost	Manual	No boost、Manual、Auto、Manual+auto	
	3:Manual tor boost level	2.2KW:4.5 1.5KW:5.0	0.0~15.0%	
	4:Man. t-b cut-off point	20.0%	0.0~100.0%	
	5:Auto tor boost level	50.0%	0.0~100.0%	

	6:Slip compensation gain	0.0%	0.0~ 300.0%	
	7:Slip comp. filter time	1.0s	0.1~25.0s	
	8:Vibration damping	20	0~200	
	9:Base frequency	50.00Hz	1.00~650.00Hz	
	10:Max. output voltage	220V	150~500V	
	11:V/F frequency F4	50.00Hz	“V/F frequency F3” ~ “Base frequency”	
	12:V/F voltage V4	100.0%	“V/F voltage V3” ~100.0%	
	13:V/F frequency F3	50.00Hz	“V/F frequency F2” ~ “V/F frequency F4”	
	14:V/F voltage V3	100.0%	“V/F voltage V2” ~ “V/F voltage V4”	
	15:V/F frequency F2	0.00Hz	“V/F frequency F1” ~ “V/F frequency F3”	
	16:V/F voltage V2	0.0%	“V/F voltage V1” ~ “V/F voltage V3”	
	17:V/F frequency F1	0.00Hz	0.00~ “V/F frequency F2”	
	18:V/F voltage V1	0.0%	0.0%~“V/F voltage V2”	
6: Motor parameters	1:Motor rated capacity	2.2KW:2.20 1.5KW:1.50	0.40~2.20kW	
	2:Pole number	4	2~48	
	3:Motor rated current	2.2KW:8.7 1.5KW:6.4	0.5~1200.0A	
	4:Motor rated frequency	50.00Hz	1.00~650.00Hz	
	5:Motor rated speed	2.2KW:1430 1.5KW:1440	125~40000RPM	
	6:Motor rated voltage	220V	150~500V	
7: Protection & advanced	1:motor overload protect value	100.0%	50.0~ 150.0%	
	2:Carrier frequency	6.0kHz	1.1~12.0 kHz	
	3:Random pwm	0%	0~30%	
	3:Jump frequency 1	0.00Hz	0.00~625.00Hz	
	4:Jumping width 1	0.00Hz	0.00~20.00Hz	
	5:Jump frequency 2	0.00Hz	0.00~625.00Hz	
	6:Jumping width 2	0.00Hz	0.00~20.00Hz	
	7:Jump frequency 3	0.00Hz	0.00~625.00Hz	
	8:Jumping width 3	0.00Hz	0.00~20.00Hz	
	10:Alarm temp of HeatSink	80℃	60℃~100℃	
	11:FoP limit hourly	2	2-5	
	12:FoP limit total	5	5-10	
	13:FoP lock status	Unlock	Unlock、Locked hourly、Locked total	
8:Multi acc/dec & freq time	1:Acceleration time2	30.0s	0.01~3600.0s	
	2:Deceleration time2	30.0s	0.01~3600.0s	
	3:Acceleration time3	30.0s	0.01~3600.0s	
	4:Deceleration time3	30.0s	0.01~3600.0s	

5:Acceleration time4	30.0s	0.01~3600.0s	
6:Deceleration time4	30.0s	0.01~3600.0s	
7:Acceleration time5	30.0s	0.01~3600.0s	
8:Deceleration time5	30.0s	0.01~3600.0s	
9:Acceleration time6	30.0s	0.01~3600.0s	
10:Deceleration time6	30.0s	0.01~3600.0s	
11:Acceleration time7	30.0s	0.01~3600.0s	
12:Deceleration time7	30.0s	0.01~3600.0s	
13:Use multi-acc/dec time	No	No\Yes	
14:Freqency1	12.00hz	"Lower-limit frequency" ~"Upper-limit frequency"	
15:Freqency2	14.00hz		
16:Freqency3	20.00hz		
17:Freqency4	60.00hz		
18:Freqency5	100.00hz		
19:Freqency6	130.00hz		
20:Freqency7	150.00hz		
21:Freqency8	0.00hz		
22:Freqency9	0.00hz		

7 Alarm

7.1 Alarm Reset

When error occurs, the computer will signal an alarm automatically with audible sound. Pressing <Enter> button will stop audible alarm sound. Press <Enter> button again after troubleshooting. If the error has been resolved or can be ignored, the computer will go back to "open" or "close" or "locked" status. Or else the computer will alarm again.

7.2 Alarm Information and Obviation

No.	Alarm Name	Troubleshooting
#1	Error door status	Please check the door switch or door pin.
#3	Over shock	Please check the capacity of machine, or the clothes knot, or check the input of over shock.
#5	Emergency stop	Pressed the emergency button, please check and release it. Or check the input of emergency stop.
#7	Inverter error	Please check the inverter, or check the input of inverter
#9	Error level sensor	Have not adjusted the level sensor, please contact with factory.
#10	Temp sensor of water	Please check temperature sensor of water, or try another one.
#11	Temp sensor of dry	Please check temperature sensor of inverter, or try another one.
#14	Overtime of fill	Can't reach the set level in time. Please check the fill valve, or check the level sensor.
#15	Overtime of heat	Can't reach the set temperature in time. Please check the device of heat, or check the temperature sensor.
#16	Overtime of drain	There are also some water in basket when drain of extract. Please check the drain valve.
#17	Lubrication time	The times of run can be browsed and be cleared by pressing [ENTER] button for 3 seconds from startup screen.
#18	Invt comm overtime	Can't receive replay data from inverter. Please check power of inverter, or the parameter of the inverter.
#19	Inverter comm intfer	Please check whether strong or weak electricity insulate or not or machine whether to connect the earth or not.
#20	PUNP inverter error	Refer to the table of PUNP inverter faults.
#21	High temp of invt	Clear cila of inverter and check the fan of inverter.
#22	W Sensor short	Please check temperature sensor of water, or try another one
#23	W Sensor break	Please check temperature sensor of water, or try another one
#33	PUNP inverter alarm	Refer to the table of PUNP inverter alarms.
#34	Clear cilia of invt	Clear cila of PUNP inverter and check the fan of PUNP inverter.
#49	Bkbd comm overtime	Can't receive replay data from I/O Board. Please check the wiring between HMI and I/O Board.
#50	Bkbd comm intfer	Please check whether strong or weak electricity insulate or not or machine whether to connect the earth or not.
#51	Parameter error	Please contact with factory.
#52	Program error	Please contact with factory.
#53	Controller failure	Please contact with factory.

7.2.1 Faults of PUNP inverter

Fault type	Possible causes	Remedies
1)Overcurrent at start	Inter-phase or grounding short-circuit inside the motor or between wirings	Check the motor and wiring
	Inverting module failed	Call us
	Voltage overhigh at start	Check the setting of "torque boost"
2)OC during acceleration	Accel time too short	Increase the accel time
	V/F curve improper	Regulate V/F curve or the setting of "torque boost"
	Running motor restarts	Set the start mode as "smooth start" Restart the motor after it stops completely
	Low power grid voltage	Check the input power
	Inverter capacity too small	Use an inverter with larger capacity
	Auto-tuning not performed for vector control	Perform the parameter auto-tuning
3)OC during deceleration	Decel time too short	Increase the decel time
	There is potential energy load or inertial torque of the load is large	Install an external dynamic braking unit
	Inverter capacity too small	Use an inverter with larger capacity
	Auto-tuning not performed for vector control	Perform the parameter auto-tuning
4)OC dur. constant-speed	Sudden change of load load error	Reduce the sudden change of the load Check the load
	Low power grid voltage	Check the input power
	Inverter capacity too small	Use an inverter with larger capacity
	Auto-tuning not performed for vector control	Perform the parameter auto-tuning
5)OV during acceleration	Input voltage abnormal	Check the input power
	Running motor restarts	Set the start mode as "smooth start" Restart the motor after it stops completely
6)OV during deceleration	Decel time too short	Increase the decel time
	There is potential energy load or inertial torque of the load is large	Install an external dynamic braking unit
	Input voltage abnormal	Check the input power
	Accel time too short	Increase the accel time
	Large load inertia	Employ a dynamic braking unit
	Improper ASR setting	Adjust ASR parameter reducing overshoot
7)OV dur. constant-speed	Input voltage abnormal	Check the input power
	Accel/decel time too short	Increase the accel/decel time
	Input voltage changes irregularly	Install an input reactor
	Large load inertia	Employ a dynamic braking unit
8)OV in standby state	Input voltage overhigh	Check the input power
	Error of DC bus voltage test circuit	Call us
9)UV during running	Input voltage abnormal or power loss during running	Check input power and wiring
	There is heavy-load impact	Check the load
	Charging contactor failed	Check and replace it
	Input phase loss	Input the input power and wiring
10)Input phase loss	R, S or T phase loss	Check the wiring
	Three input phases imbalanced	Check input voltage
	Serious oscillation of output	Adjust parameters to eliminate the oscillation
11)Output phase loss	Loss of output (U, V or W)	Check the output wiring Check the motor and cables
	Output has interphase short-circuit or grounding short-circuit	Rewire
12)Power device protect.	Wiring of or components on the control board loose	Check and rewire
	Wiring of the motor or inverter too long	Add output reactor or filter
	Overcurrent of braking unit of 15kW inverter or below	Check the external braking resistance and wiring
	Serious interference or failure of inverter	Call us
	Ambient temperature overhigh	Lower the ambient temperature
13)Inverter overheating	Air path blocked or the fan failed	Clean air path or replance the fan
	Load too heavy	Check the load or select an high-capacity inverter

14) Inverter overload	Load too heavy	Check the load or select an high-capacity inverter
	Inverter temperature too high	Check the fan, air path and ambient temperature
	Accel time too short	Increase the accel time
	Carrier frequency too high	Lower the carrier frequency or select an inverter with a higher capacity
	V/F curve improper	Regulate V/F curve and torque boost level
	Running motor restarted	Set the restart mode as “smooth restart” or “restart after motor stops”
	Input voltage too low	Check the input voltage
15) Motor overload	V/F curve improper	Correctly set the V/F curve and torque boost level
	The common motor runs with heavy load at low speed for a long time	Install a separate cooling fan or select a motor designed for inverter
	Improper setting of nameplate parameters or overload protection	Set FA-03, Fb-00 and Fb-01 correctly
	Motor stalls or load changes suddenly and greatly	Check the load
16) External fault	External fault terminal closed	Deal with the external fault
17) Motor load overweight	Motor current exceeds the load overweight detection level, and the detection time is exceeded	Check the load Check the setting of load overweight protection
18) Inverter underload	Inverter output current is less than the underload protection level, and the detection time is exceeded	Check the load Check the setting of underload protection
19) C1 output protection	Generated by comparator 1	Check the definition of comparator 1 output
20) C2 output protection	Generated by comparator 2	Check the definition of comparator 2 output
21) Parameter saving fail	Failure in writing parameters	Retry after reset. Call us if problem still exists.
22) Communication error	Improper setting of communication parameters	Check the settings of FF menu
	Serious communication interference	Check the wiring and grounding of the communication circuit
	PC does not work	Check PC and wiring
23) Current test error	Loose wiring or components inside the inverter	Check and rewire
	Failed current sensor or circuit error	Call us
24) standby		
25) standby		
26) standby		
27) Thermal resistor open	Thermal resistor disconnected	Check the connection of thermal resistor or call us
28) standby		

7.2.2 Alarms of PUNP inverter

Alarm name	Description	Remedies
1)Motor overload	Motor thermal model detects the motor temperature rise is overhigh	Refer to above table
2)Motor load overweighth	Motor current exceeds the load overweight detection level, and the detection time is exceeded	Refer to above table
3)Inverter underload	Inverter output current is less than the underload protection level, and the detection time is exceeded	Refer to above table
4)standby		
5)standby		
6)standby		
7)Input phase loss	Lack of input phase or imbalance among three phases	Refer to above table
8)Output phase loss	Lack of output phase	Refer to above table
9) standby		
10)Parameter saving fail	Failure in writing parameters	Refer to above table
11) standby		
12)DC link undervoltage	DC link voltage is lower than the threshold	It is normal for this alarm information to be displayed when the power is off
13)C1 output protection	Generated by comparator 1	Check the definition of comparator 1 output
14)C2 output protection	Generated by comparator 2	Check the definition of comparator 2 output
15) standby		
16) standby		
17) standby		
18)Parameter check error	Improper parameter setting	Correct parameter setting or restore factory setting.