

# INSTRUCTION MANUAL



Thank you very much for having brought our products.

Don't fail to fulfill the matters that demand special attention to be mentioned below so that you could put this machine to use for a long time with safety.

Don't fail to read the user's manual first of all when you've come to hand the machine.

Ensure the machine type you've brought prior to use, as this user's manual is the one for the 450C.

Ensure ration table of the main unit of the machine as well as style and design of the manipulation panel or those of the unit, referring to the illustrations on the user's manual or the catalogue.

Don't use the machine and bring into contact with the store you had bought it as early as possible when you've found your machine to be different from the very one you had ordered and so forth. Keep this user's manual with care and read it as occasion demands.

Ensure the accessories things.

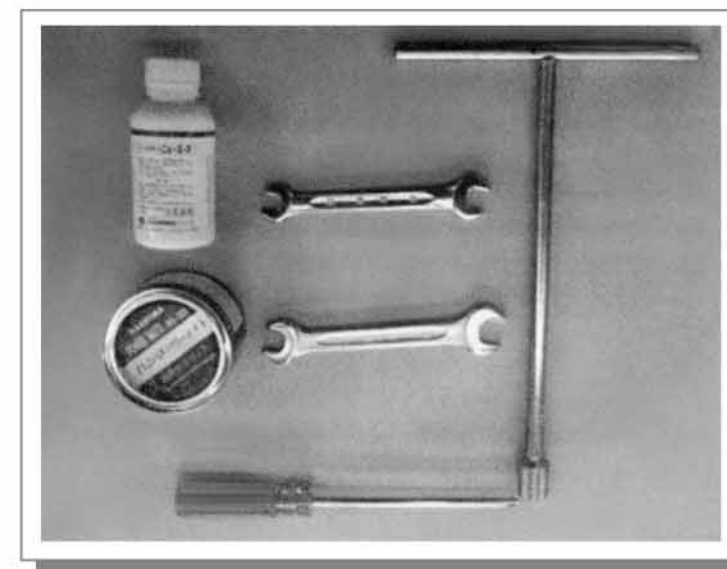



## ATTENTIONS TO BE PAID FOR SAFETY



## DON'T FAIL TO FULFILL

You should fulfill following explanations for the prevention of the user and the others from being hurt and the proprieties from being damaged.

○ We divide and explain you the degrees of peril and damage to be taken place when you'll neglect the contents of the display and use the machine erroneously.

 <b>DANGER</b>	This display tells you contents that imagine "the imminence of the danger that might result in death or a serious injury".
 <b>WARNING</b>	The display tells you contents that imagine "the possibility of death or a serious injury".
 <b>CAUTION</b>	This display tells you the contents that imagine "the possibility of resulting in be to handicapped or material damages exclusively".

○ We divide and explain you the contents you should fulfill in accordance with the following illustration (Following is an example of the illustrations).

	This illustration tells you the contents "that demand attention" you must pay.
	This illustration tells you the contents of "prohibition" you should not do at all.
	This illustration tells you the contents of "enforcement" you should executive without fail.

 **DANGER**

 **Don't get the children to use where the infants can make contact with**

For fear of burn, electric shock and injury.

 **Never reform at all**

For fear of fire and injury due to unusual movement.

**Disassembly prohibited**

 **WARNING**

 **Don't disassemble and repair absolutely except the repair technician**

For fear off fire and injury due to unusual movement.

**Disassembly prohibited**

(Contact to the dealer for repair in the case of damage and troubles.)

 **Connect with the power source with ratio consumption suitable to the machine and don't fail to ground**

Unusual heat might in fire or electric leak when you put the machine to use along with other apparatus.

(Contact to the electric construction work shops nearest by.)

 **Disconnect the power source (the plug and installed breaker)out of the origin**

For fear of burn as well as electric shock and leak in fire.

 **WARNING**

 **Please maintain the machine after cutting the power supply breaker, and falling the temperature of the machine**

It causes the burn and the injury.

 **Please don't touch the machine and belt by your hand**

It causes the burn and the injury.

Be careful enough when you touch the machine.

 **Be careful enough when you insert the material**

It causes the burn and the injury because apart of clothing or body is sandwiched between machine parts.

Be careful enough when you touch the machine.

 **Don't mount nor put things on the main unit**

For fear of high temperature might result in burn and fire there is a possibility of falling down to be injured.

 **Install the machine on the robust or onto the floor horizontally**

For fear of overturning or falling down resulting in injury.

 **Don't put things easy to burn around the machine**

For fear of causing fire and so on.

 **CAUTION**

- Don't install the machine to the site high humidity(For fear of causing electric leaks).
- Don't bend nor crush the power source cord(For fear of electric shock and shortage, resulting in fire).
- When a manual handle is used it turns off power without fail. Moreover, a manual handle removes things except use and the hole cover is put without fail(The manual handle rotates and there is rapidly injured fear).
- Don't let the people go near by except operator.

**PETITION**

- There is a thing that the cover becomes very hot depending on the use temperature because this machine is used according to the high temperature. Please note a burn and combustible clothes, etc. enough.
- Please confirm the thing that stops with the timer, and cut the power supply breaker after the end of work.
- Please cut the power supply breaker without fail, and go in the state that the temperature of the machine gets cold then the material that caught under around the strip off device or scraper are removed. Moreover, when you take the finished material out of the exit, pay attention not to be caught in the strip off device.
- Clean the belt with a well dried floor cloth when the operation is over. But, reduce the belt speed with sufficient attentions at the exit side of the finished material of the machine for fear of such accidents as burn and caught in.
- Please check the belt cleaner every day. Moreover, please refuel to each part once a month to prevent the accident occurs. You must keep the electric source off and be cool.
- Please understand enough, and operate working of switches.
- Please open space necessary for maintenance in surroundings of this machine.
- The machine have emergency stop switch when the belt over moves left or right. Please take out the material with the manual handle of the attachment after it turns off power without fail when a material stops in the machine due to the emergency switch works or the power.

By putting "alarm label" onto every part of the machine, we rouse you to prevent the user and others from being hurt and proprieties from being damaged.

- Ensure the position and contents in regard to the "alarm label" prior to the use.
- Never remove nor reform the "alarm label" .
- Put a new one as early as possible, when the old "alarm label" is hard to read or when it is come off.

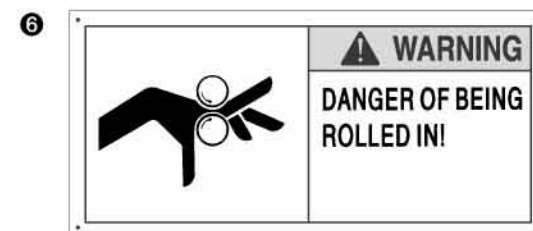
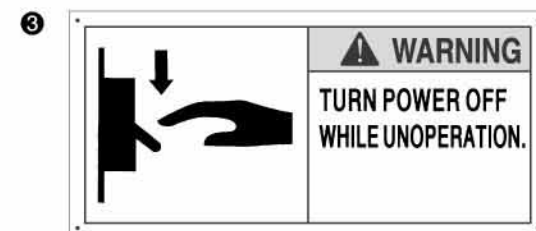
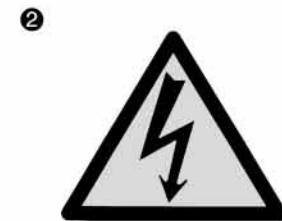
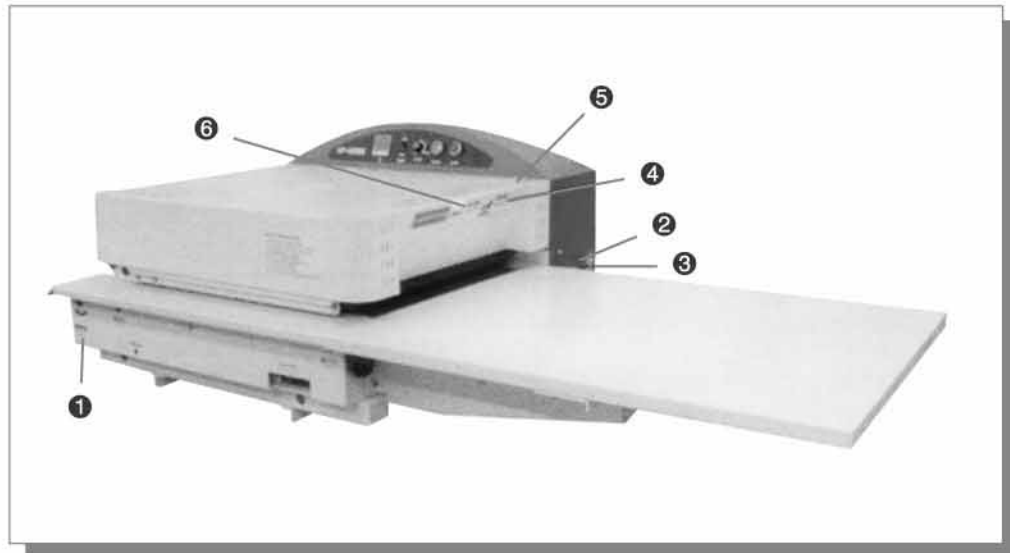

**SPECIFICATIONS**

<b>MODEL</b>		<b>450C</b>
<b>POWER SUPPLY</b>		1P-220V
<b>RATED OUTPUT</b>	HEATER	4kw
	MOTOR	45w
<b>TEMPERATURE(MAX)</b>		195℃
<b>PRESSURE(MAX)</b>		1.5kg/cm
<b>BELT SPEED(MAX)</b>		8.7m/min
<b>HEATING TIME</b>		5-20sec
<b>FUSING WIDTH</b>		450mm
<b>DEMENTIONS</b>	W	1660mm
	D	880mm
	H	490mm
<b>WEIGHT</b>		152kg

**DESIGN FEATURES**

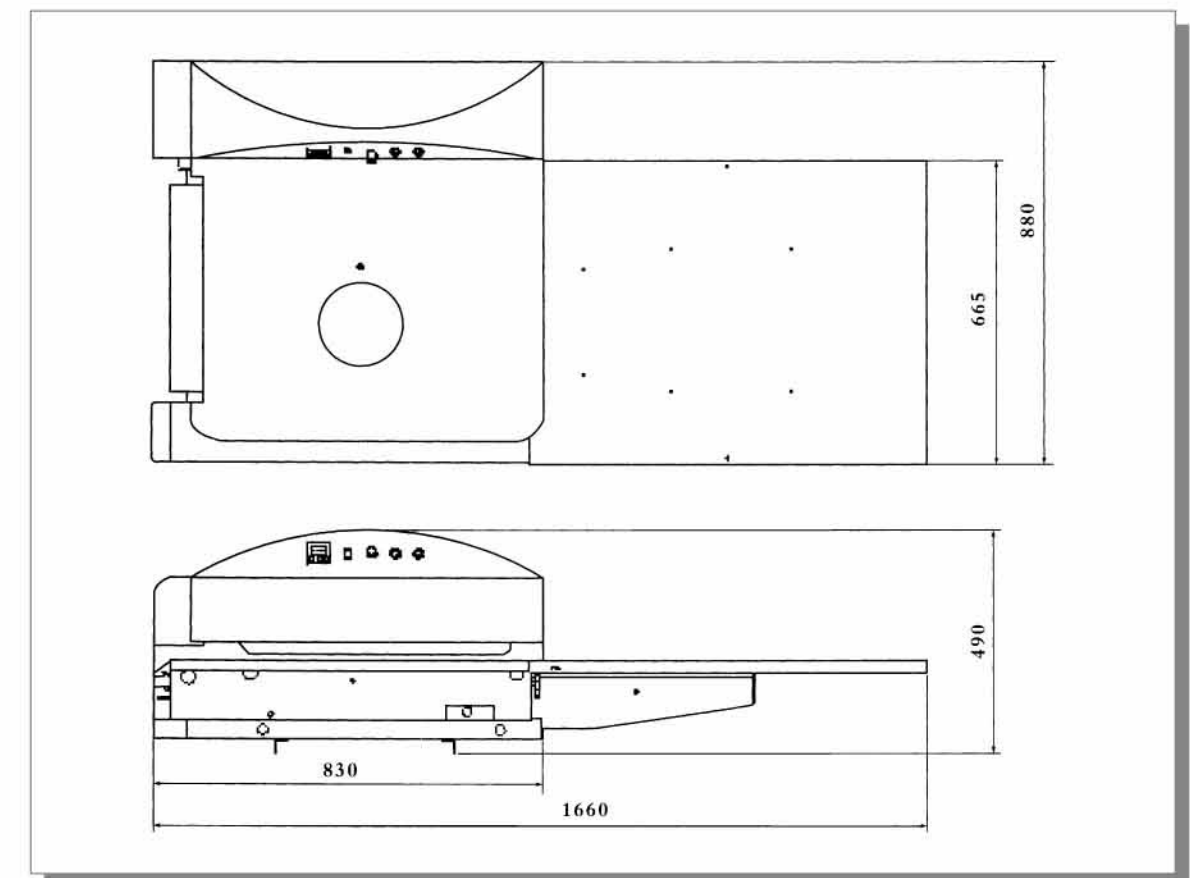

### Attention to be paid at the time of installation

- Install this machine, which weights 152kg, in regard to the 450M/MS respectively, on the robust foundation horizontally.
- Don't install this machine near the object easy to burn, as it generates high temperature when it has been put into use. Exclude, in addition, dusts and others stuck onto this machine periodically.
- Connect the machine to an exclusive power source corresponding with the ratio consumption power by referring to the specifications.
- Don't fail to the ground. By the way, it has no relations to the rotary direction of the belt.
- In the case where you change the power source plug or lengthen construction shop near by.
- When the machine has been brought in or when it has been transferred, don't fail to remove the main unit's cover, before ensuring that the upper and lower belt warping prevention limit switches place correctly the belt between them from both sides (Refer to next page).

### Attention to be paid at the time of using

- Don't fail to read the User's Manual prior to the usage.
- Don't fail to remove the main unit's cover and ensure that the upper and lower warp prevention limit switches place correctly the belt between them from both sides, before connecting the power source(Refer to next page).
- Wipe off dusts using a dry floor mat, before inserting the material.
- Pay sufficient attention not to make contact with the belt and the upper cover whose temperature rises high nor mount things on them.
- Don't absolutely put your hands on to the roller inside the machine beyond the necessity at the time you insert the material for fear that they might be caught in.
- Don't any things to the main unit of the press except the materials to be inserted.
- Disconnect the power source breaker immediately and insert the manual handle (an accessory) to the emergency screw, then, turn it to the arrow marked direction in order to remove the unusual things before the operation, if they have been inserted.
- When the material, has twined rounded the strip off device at the exit of the material, don't fail to disconnect the power source breaker, before removing it.
- Don't fail to pull the power source plug off when you inspect the inside.
- This machine is an exclusive use for fusing and folding the clothes. Don't put it to use for other purposes, otherwise resulting in troubles.
- After the operation ensure that the machine has stopped completely, before disconnecting the power source breaker without fail.

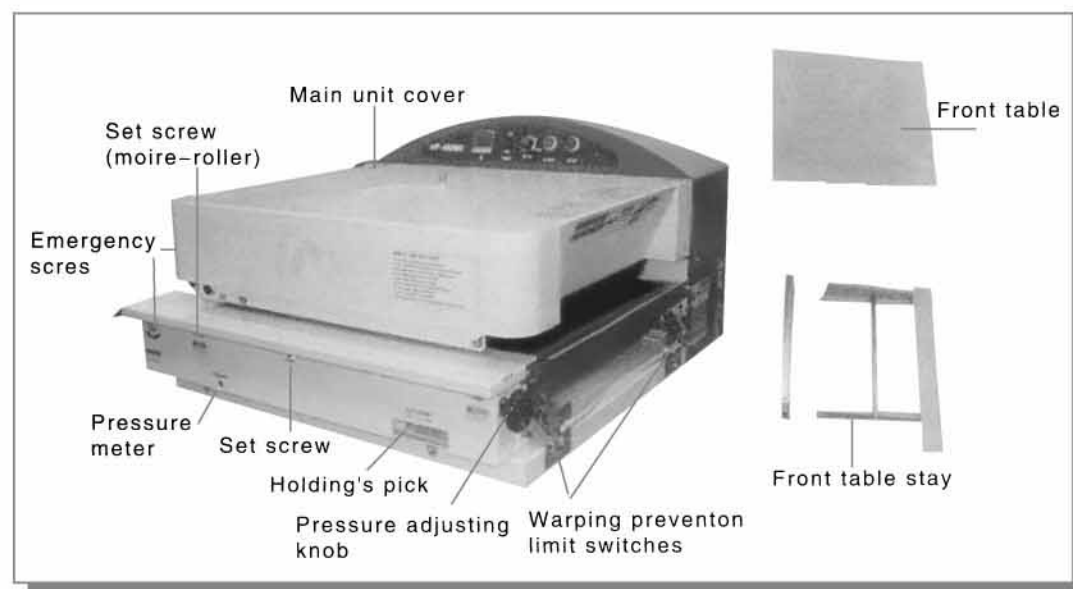

### Procedure of usage

- Set the power source to 'ON'(Ensure the 'off' condition of the timer switch).
- Press the start button. The lamp will light up and the machine will start moving.
- Set pressure to the designated by using the pressure adjust knob.
- Set the fusing time by using the speed controller. Use it within the limit between 5 and 20 seconds for the warp prevention.
- Set the setting temperature by using the thermostat. It takes about 15 minutes before you'll get the usable thermo-lamp will start blinking.
- Here, you are able to start the operation.

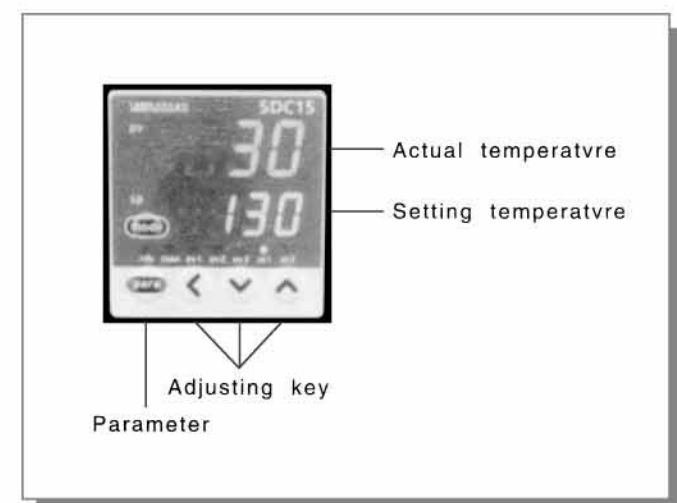
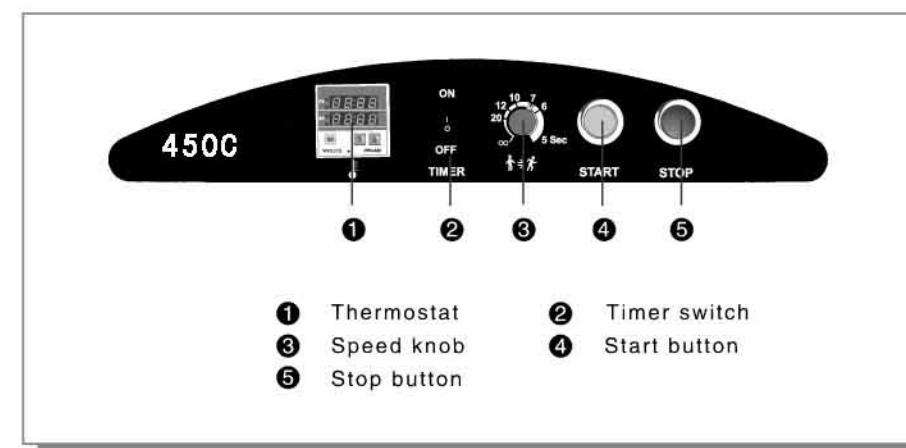

**At the time the operation is over.**

- Set the pressure to 0(zero).
- Set the timer switch to 'ON'. The machine stop automatically and the surface temperature of the belt is below 90 degrees.
- When the machine has stopped, set the power source breaker to 'OFF'.

**The holding's adjustment**

In the case where you want to strengthen the holding at the injecting entrance of the machine when you've put the inside belt scale, pocket folding and others to use, turn the holding's handle to the right. Set the holding's adjustment to 0(zero), when you try to fuse the inter lining.

**How to prevent and adjust roller moir é (puckering)**

In the case where roller moir é has taken place on the fused material, fuse it by lowering heat and pressure as low as possible. Even when the prevention is impossible in spite of the efforts, adjustments to be shown below will be necessary.

- Remove the main unit's cover.
- Remove the rear cover.
- You'll find a screw for securing the moir é adjust roller on the side of the machine. And you will find an other when you open the rear cover of the machine loosen both of the stop screws and rise right and left equally.
- The moir é is hard to appear when you bring up the roller.
- Tighten both of the stop screws.

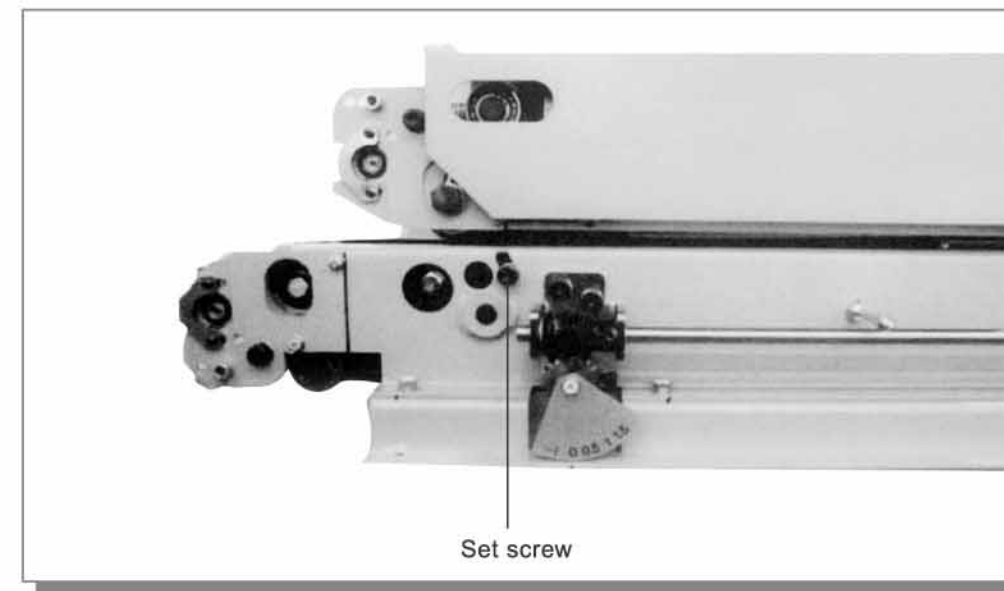
**How to move the machine by hand at the emergency**

Press the stop switch in order to stop the machine before setting the pressure to 0 (zero), when you've put other things to the belt's injecting entrance by mistake. Put the T-typed wrench (an accessory) on to the screw for emergency on the side of the main unit and turn it to the arrow marked direction, before you will unload the finished material. In the case where a hard thing has been put in the machine, ensure the safety before resuming the operation for fear that the teflon belt and rubber parts of the pressure roller might be damaged. And in the case of an electric failure, put the T-typed wrench (an accessory ) on to the screw for emergency use on the side of the main unit and turn it to the arrow marked direction. before you'll unload the finished material



## Daily maintenance (Pay attention to fear such accidents as burn and caught -in)

### Cleaning belts

Clean the belt while it is hot. Use the butyrous or the New Clean Spray to clean the belt. In the case where you put the latter to use, pay attention not to spray such electric parts as the warp prevention limit switch and others, resulting in troubles. Moreover, don't use the powders New Cleaning except when dirt is remarkable. Wipe with sure the powders which have a character to be hardened when it is cool. Apply the butyrous onto the belt for the prevention of dirt.

### Cleaning the cleaner

The cleaner is provided at the rear part of the machine. At the start of the cleaning, don't fail to pay attention so that the clean surface could make contact with to belt. And observe it about twice a day to change the dirty surface if necessary. The cleaner is to be removed when you push it to the manipulation panel's side. When you wind a new cloth, make it coincide with the rotary direction of the belt and, then, wind it, not being caught in.

### Cleaning the brush scraper (M)

The brush, too, is provided at the rear part of the main unit of the machine. Raise the scraper three or four times a day in order to clean.

### Cleaning the rotary strip off blade (MS)

Pick the blade, using a piece of the cloth and move it left to right and right to left in order to take the fusing resin resin and others away. Here, if the blade remains lying, raise it before cleaning it.

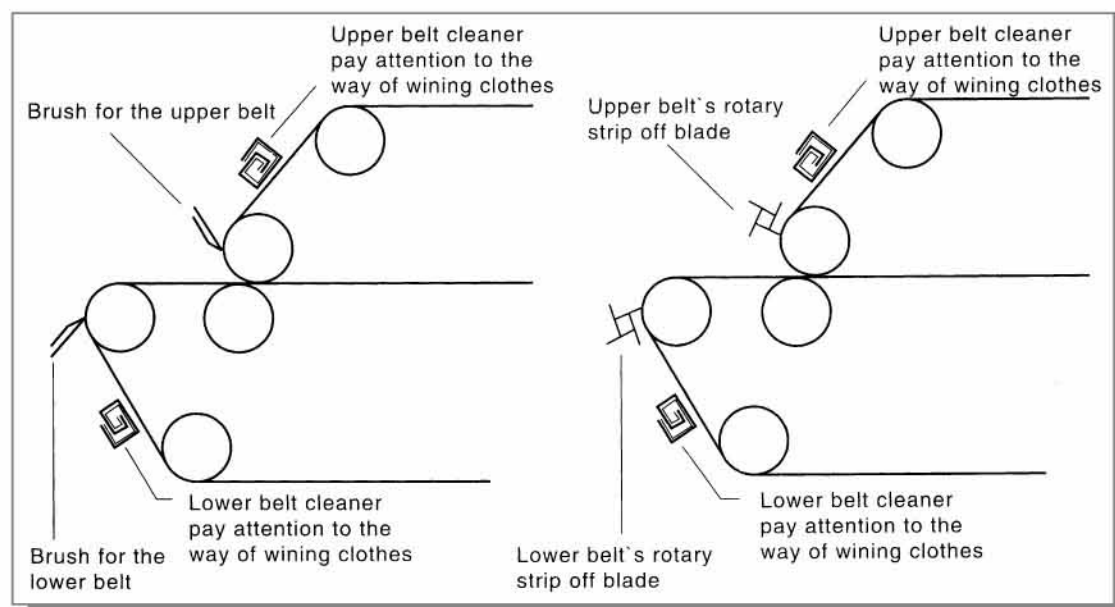

## ATTENTION TO BE PAID MAINTANANCE OF FUSING MACHINE

Put-off electric sources, fill "grease" inside rollers every two weeks. You should use the provided weijie grease and never use grease which contains MOLYBDENUM (LACK OF THIS GIVES DAMAGES TO BEARINGS)

- TAKE OUT MAIN COVER A.
- FULL GREASE INTO THE PLACE OF ARROW MARKS.

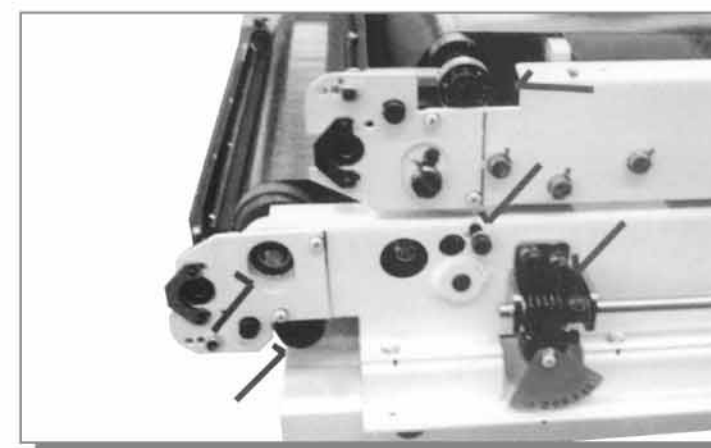
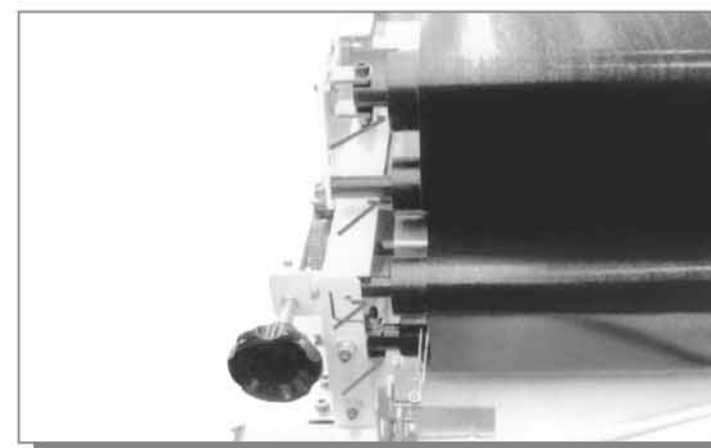
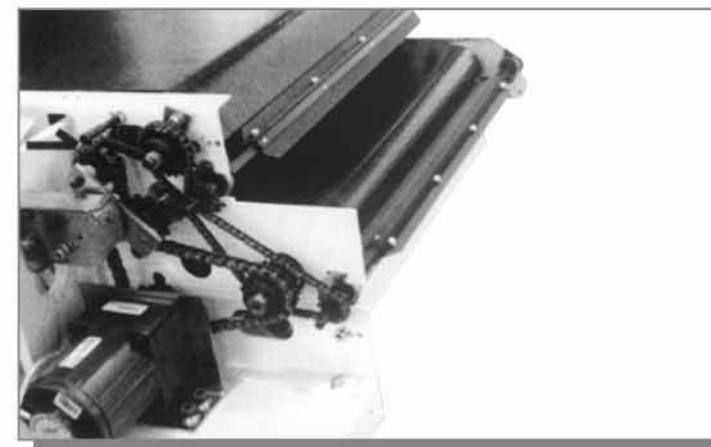

## HOW TO EXCHANGE UPPER BELT

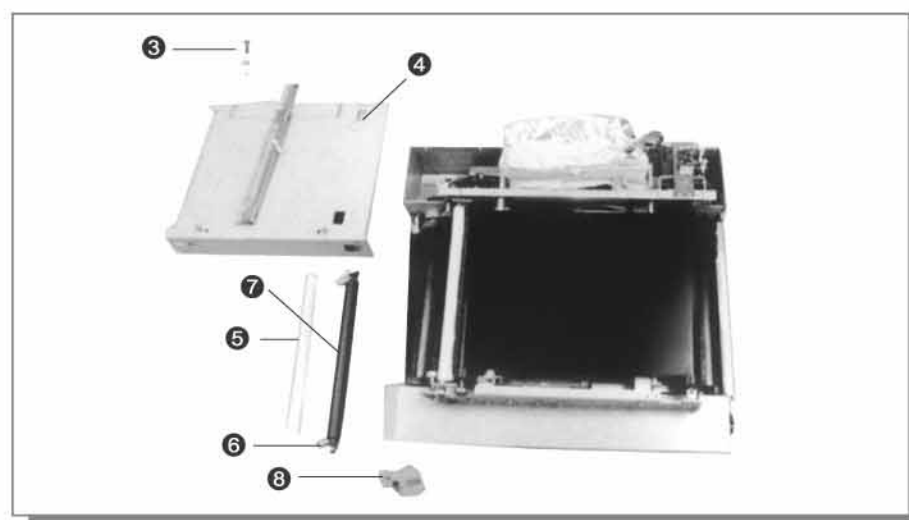
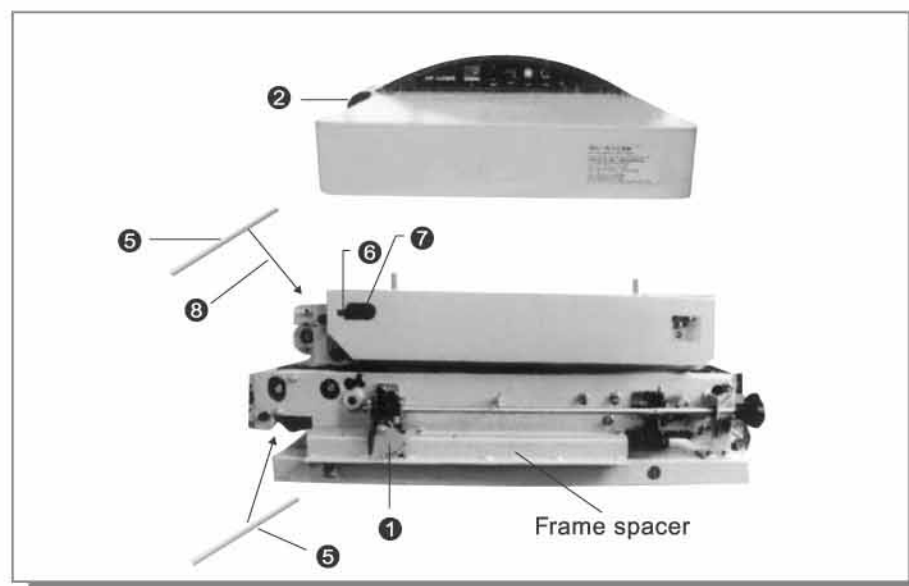
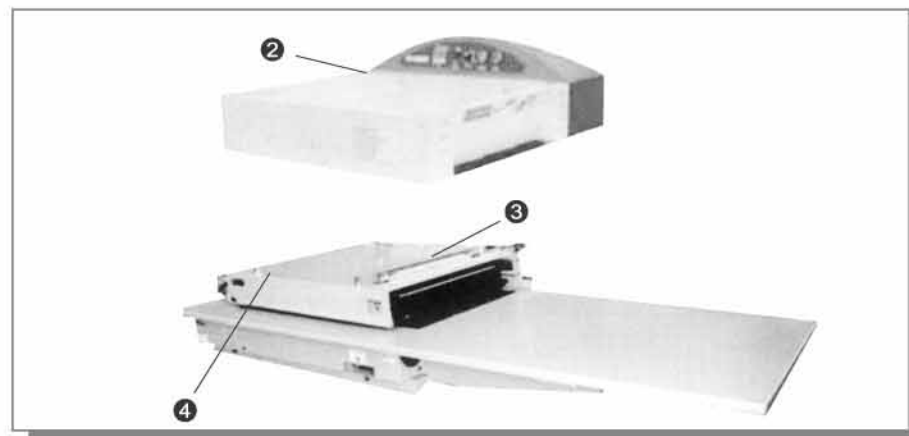

- ① Disconnect the power source from its origin and set the pressure -1, and pull-in adjuster set to 0.
- ② Take off main cover (A). Take off screw of main cover (panel side) and put it near the machine or take off connector of panel side and control box.
- ③ Take off belt warping prevention limit switch stay. 3 pan screw(yellow marks).
- ④ Take off the adiabatic cover. 2 Pan screw, 2 Hex bolt (yellow marks).
- ⑤ Take the cleaner bar(upper) off.
- ⑥ Take the tension spring (upper) off of both side.
- ⑦ Take the tension roller (upper) off.
- ⑧ Take the blade stay (lower) off. 2 hex bolt (yellow marks).
- ⑨ Take off a belt from upper frame. When change upper belt, it is easier by taking off frame spacer. In this case, take off front table, working table, sub-table, belt protection stay and left frame support stay(Refer how to change lower belt).
- ⑩ Reassemble in the reverse order.

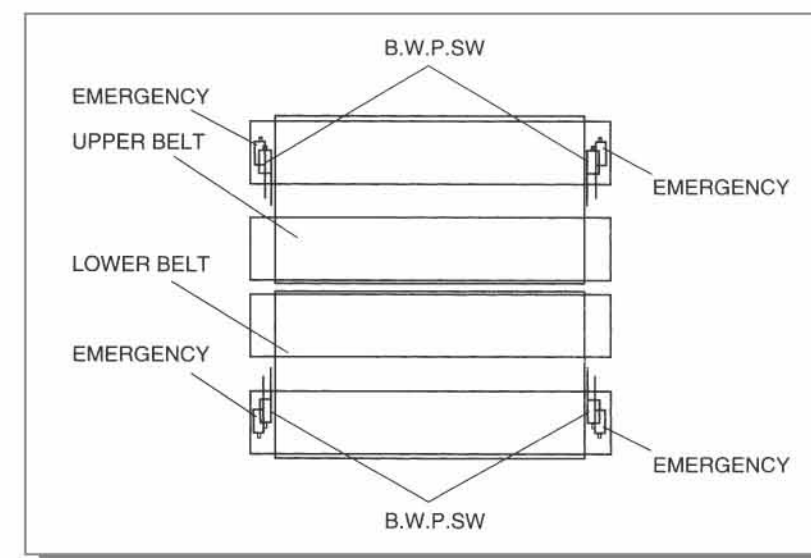

## HOW TO CHANGE LOWER BELT

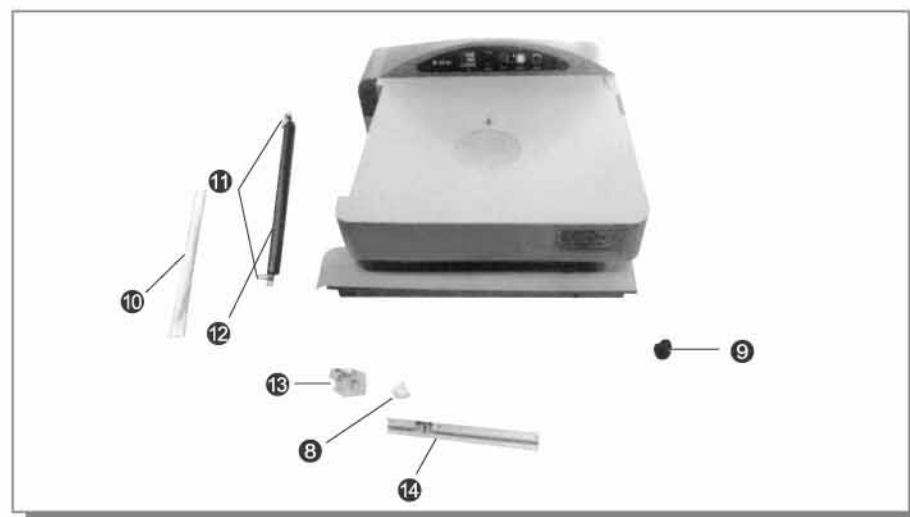
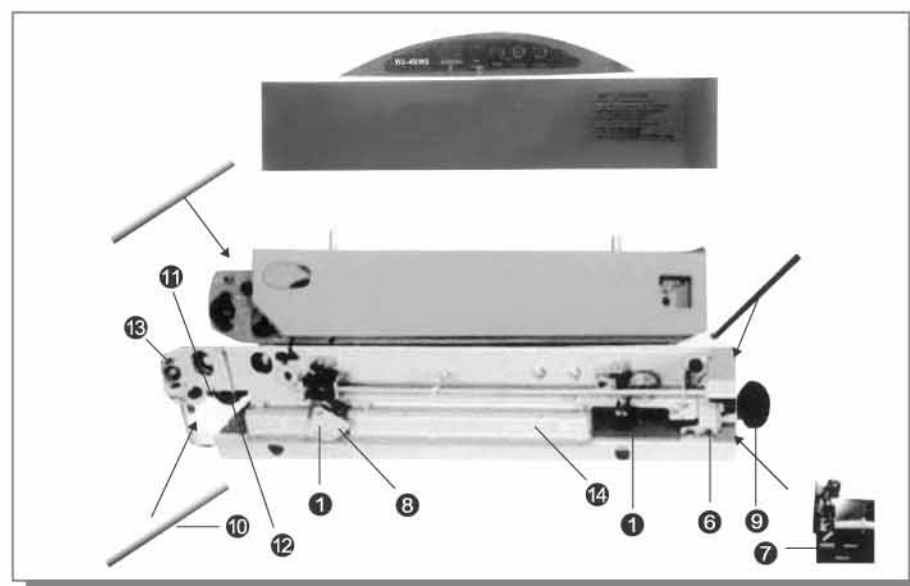
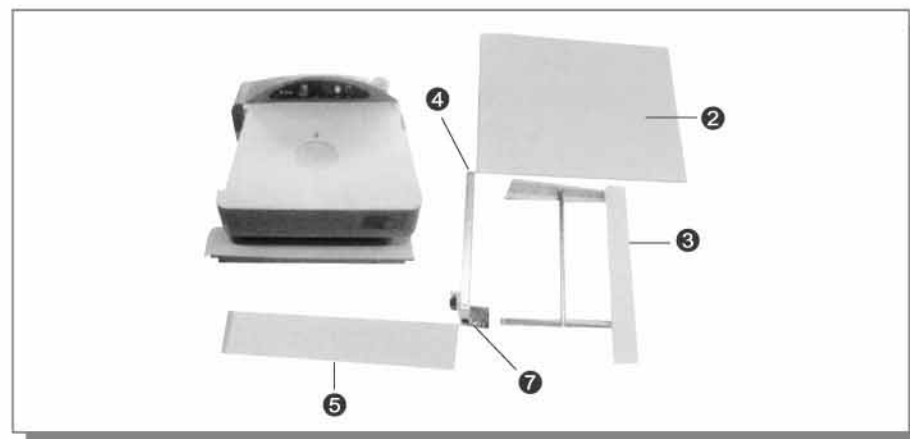

- ❶ Disconnect the power source from its origin and set the pressure to -1 by the pressure adjusting knob. Set the holding's adjustment to 0.
- ❷ Take the front table off.
- ❸ Take the front table stay off.
- ❹ Take the belt protection stay off. Pan screw 2 (yellow mark).
- ❺ Take the side table off. Hex. Nut 1 (yellow mark).
- ❻ Take the left frame support stay off. Hex. bolt 2 (yellow mark).
- ❼ Take the left lower belt warping prevention limit stay off. Pan screw 2 (yellow mark).
- ❽ Take the pressure meter off. Hex. bolt 1.
- ❾ Take the pressure adjusting knob off. Hex holed set screw 2.
- ❿ Take the cleaner bar (lower) off.
- ⓫ Take the tension springs (lower) off.
- ⓬ Take the tension roller (lower) off.
- ⓭ Take the blade stay (lower) off.
- ⓮ Take the frame spacer off. Hex. Bolt 3 (yellow mark)
- ⓯ Press the belt through the outside of the lower frame in order to pull it out. When change lower belt, it is easier by taking off upper cover.
- ⓰ Reassemble in the reverse order. Give attention to set the position of the pressure Meter and left lower belt prevention limit stay.

# 1 总体图

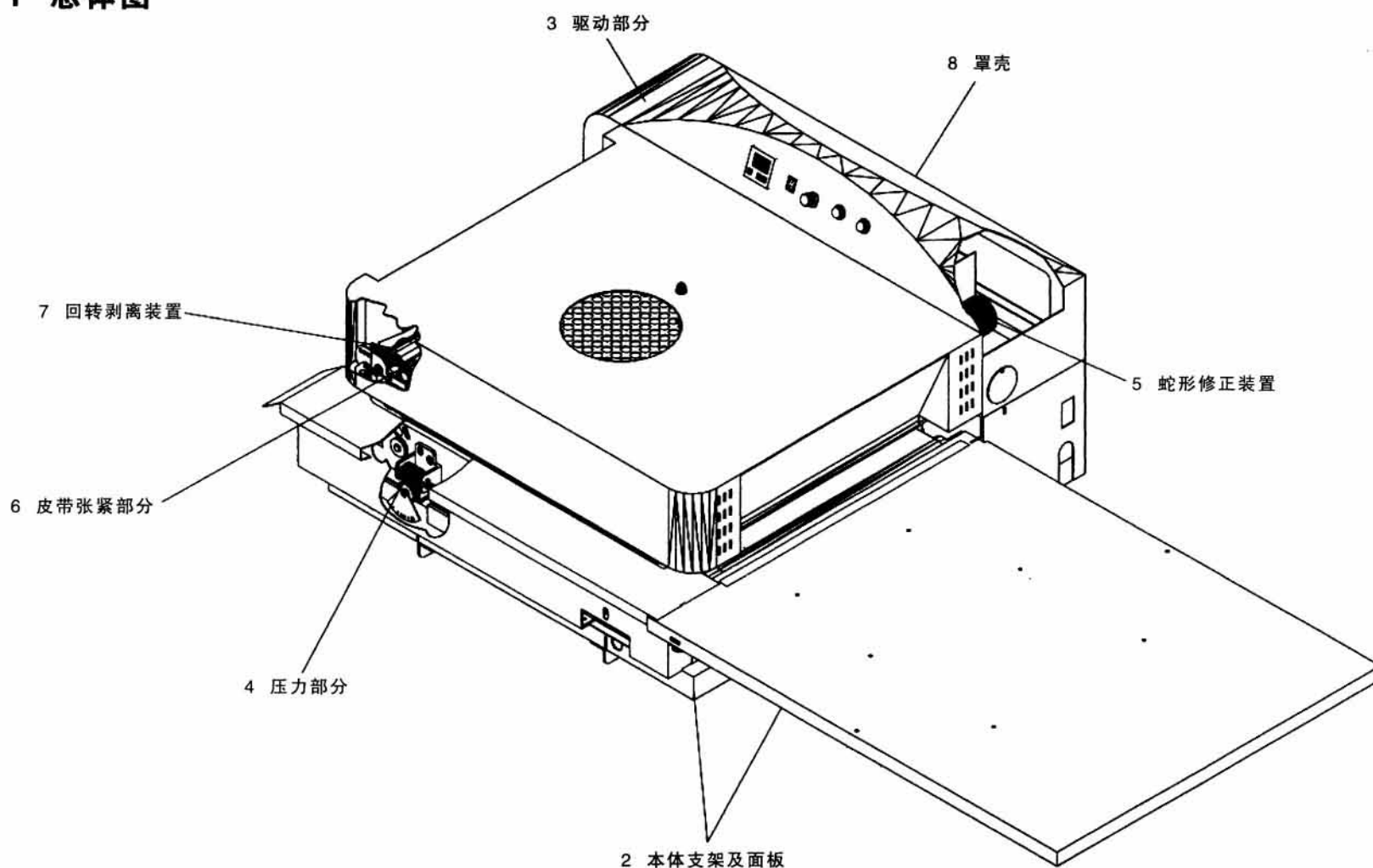

33

# 2 本体支架及面板

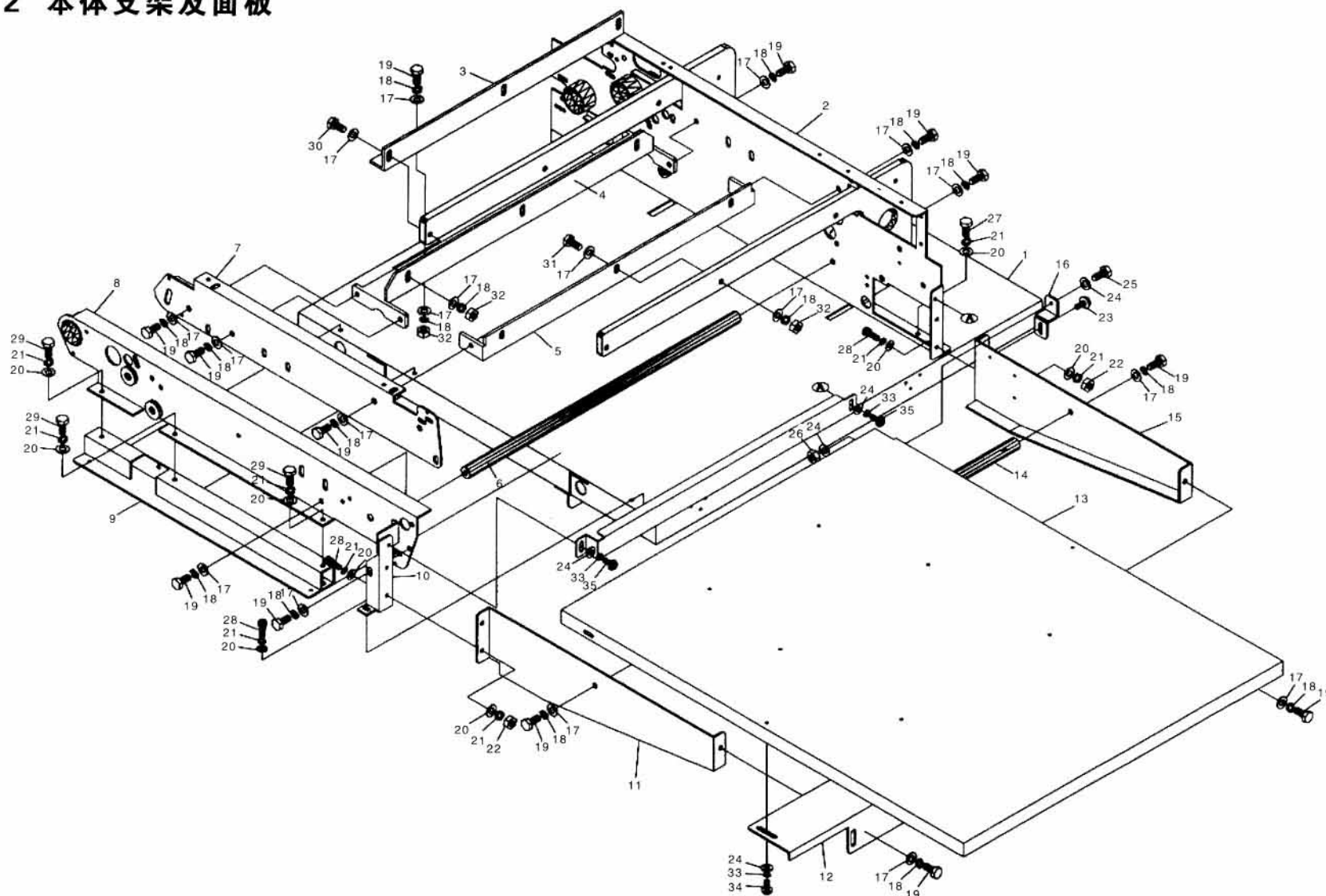

34

### 3 驱动部分

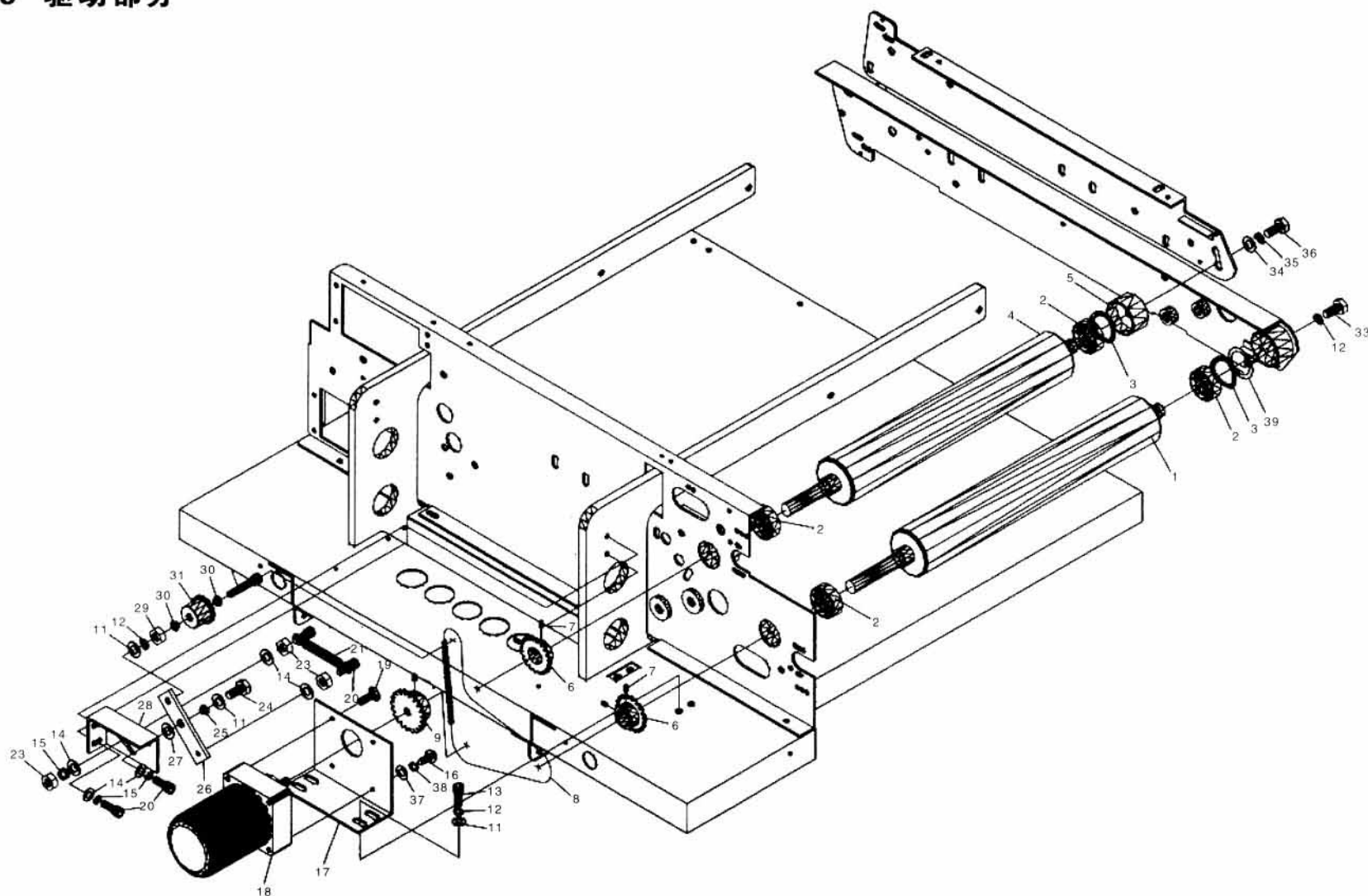

35

### 4 压力部分

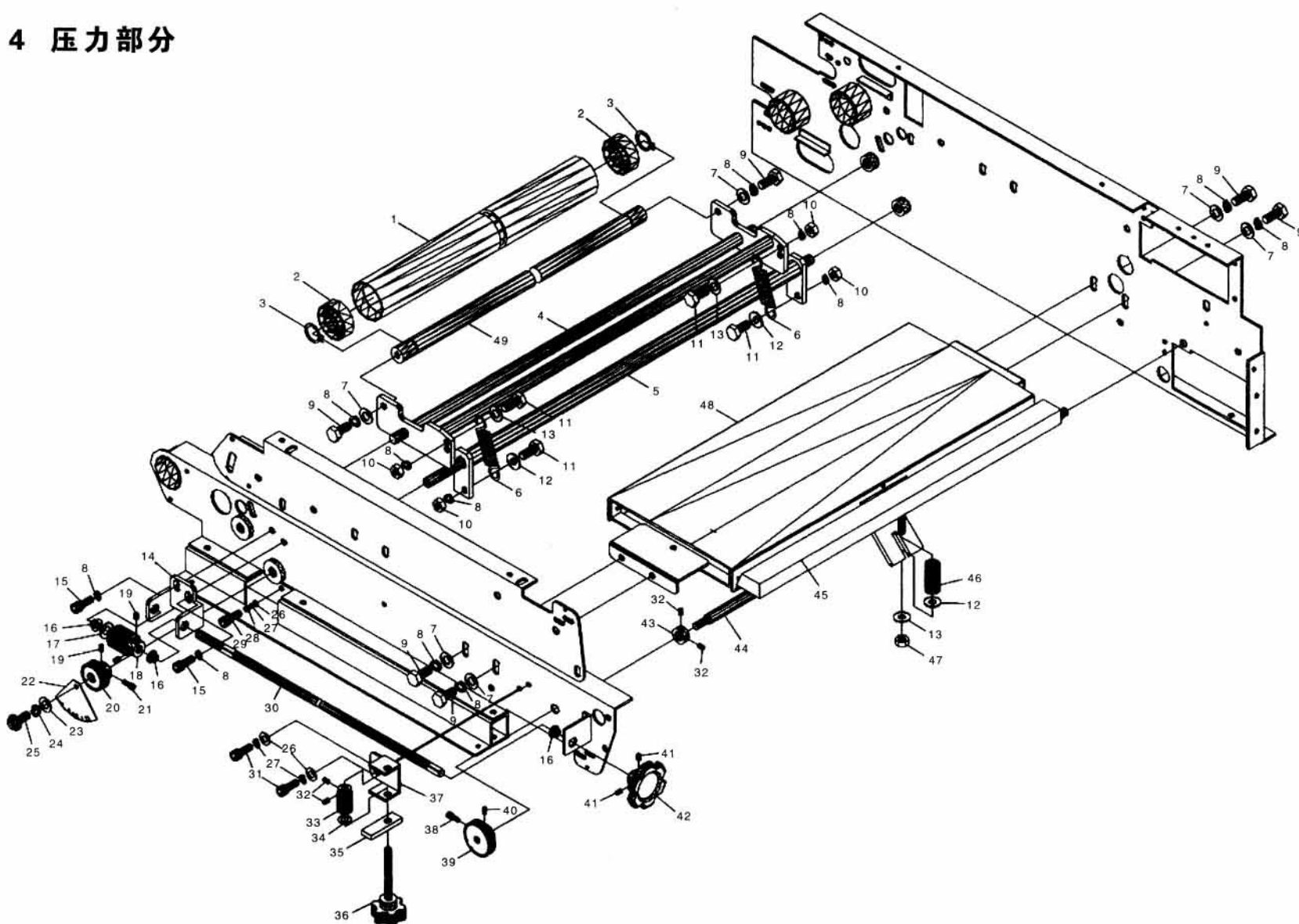

36

### 5 蛇形修正装置

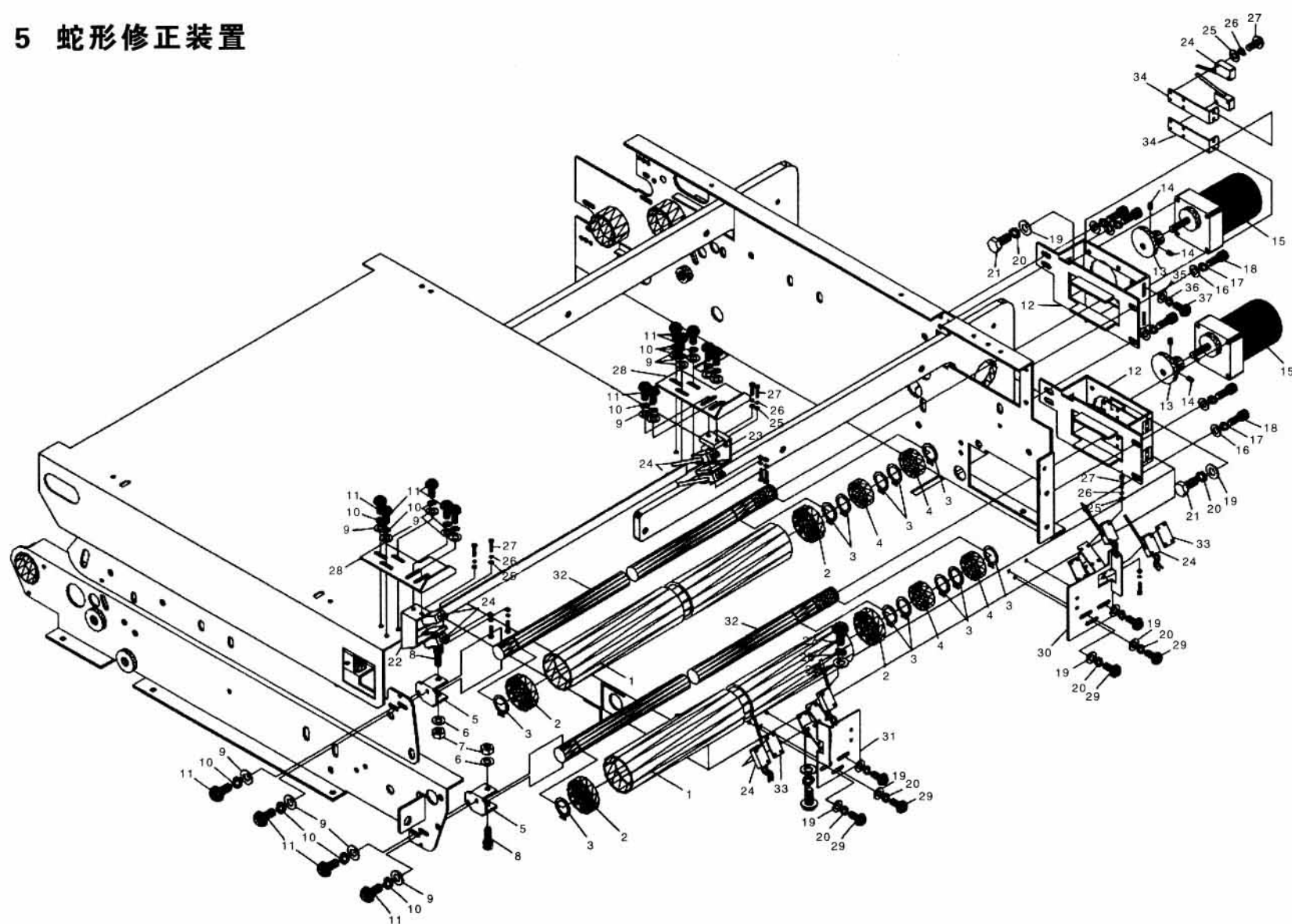

37

### 6 皮带张紧部分

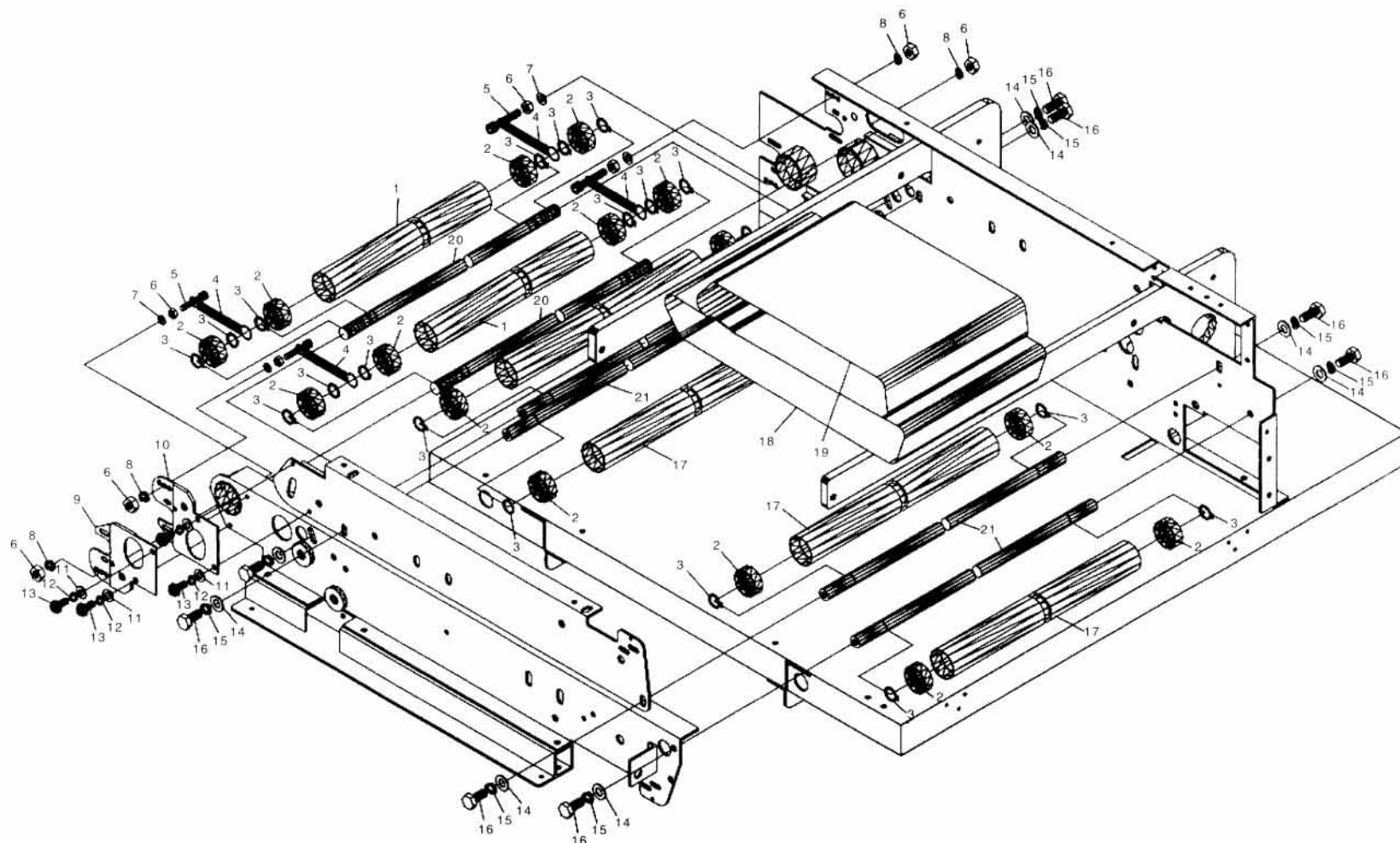

38

### 7 回转剥离装置

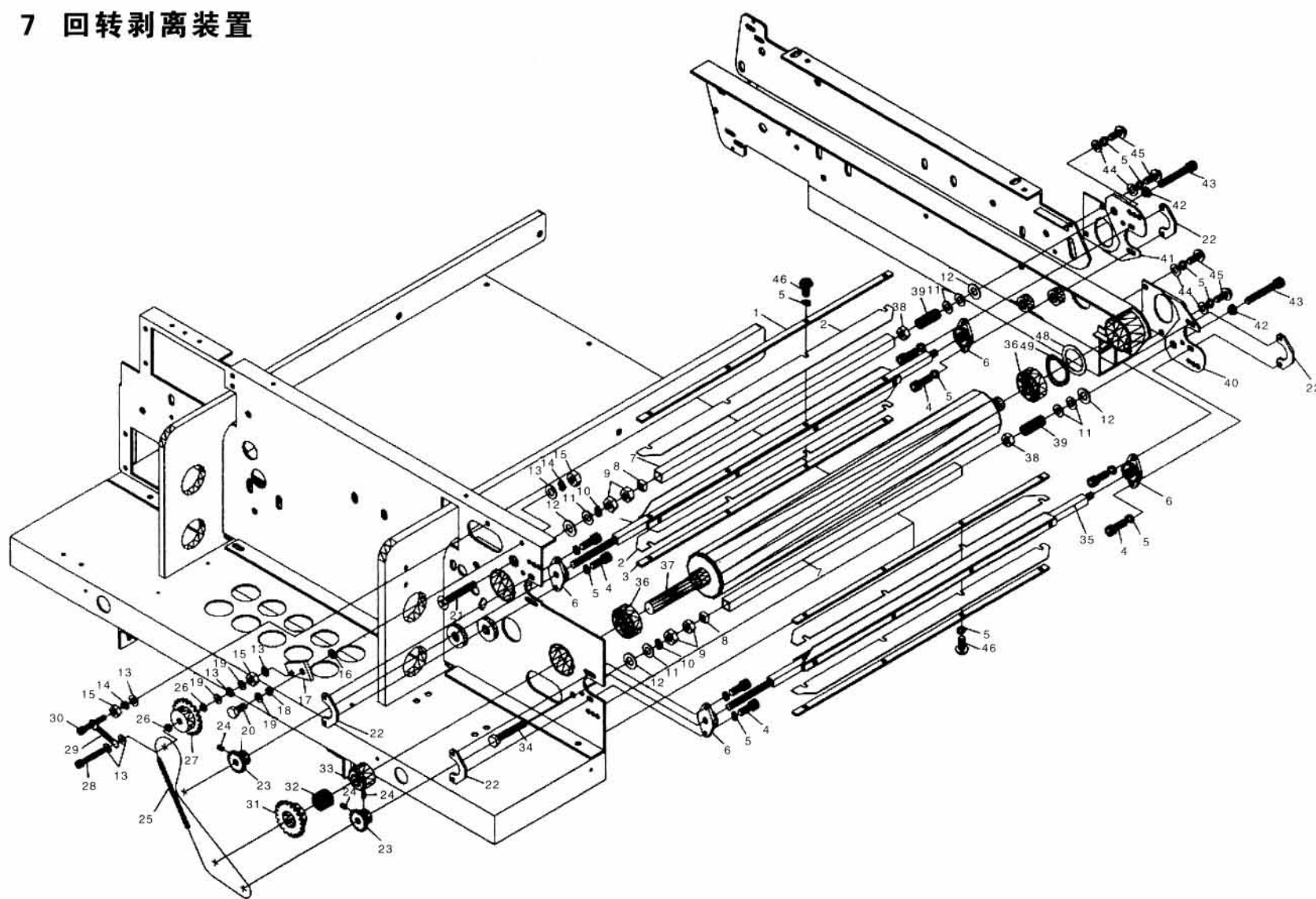

39

### 8 罩壳

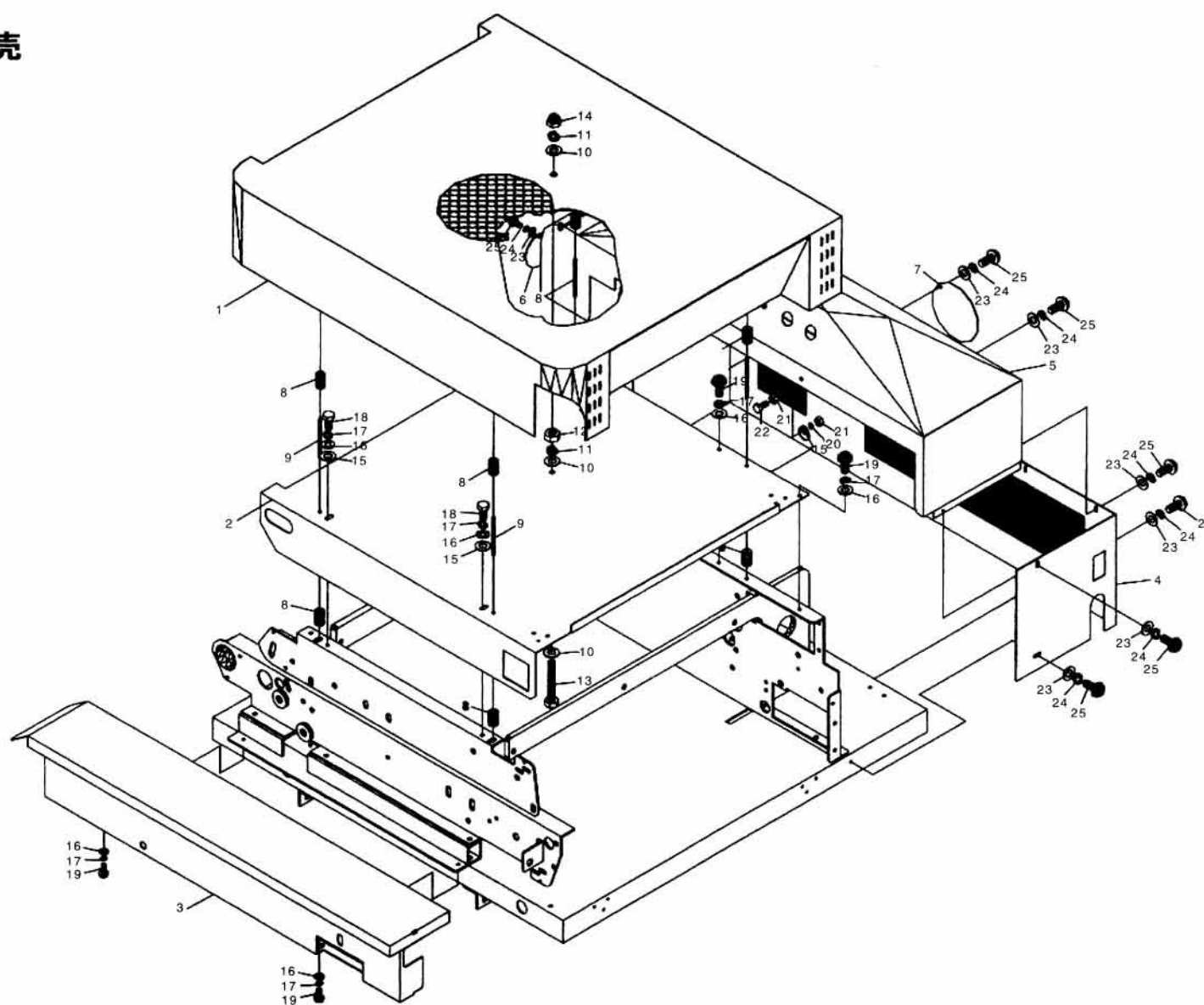

40

### 9 刮板装置

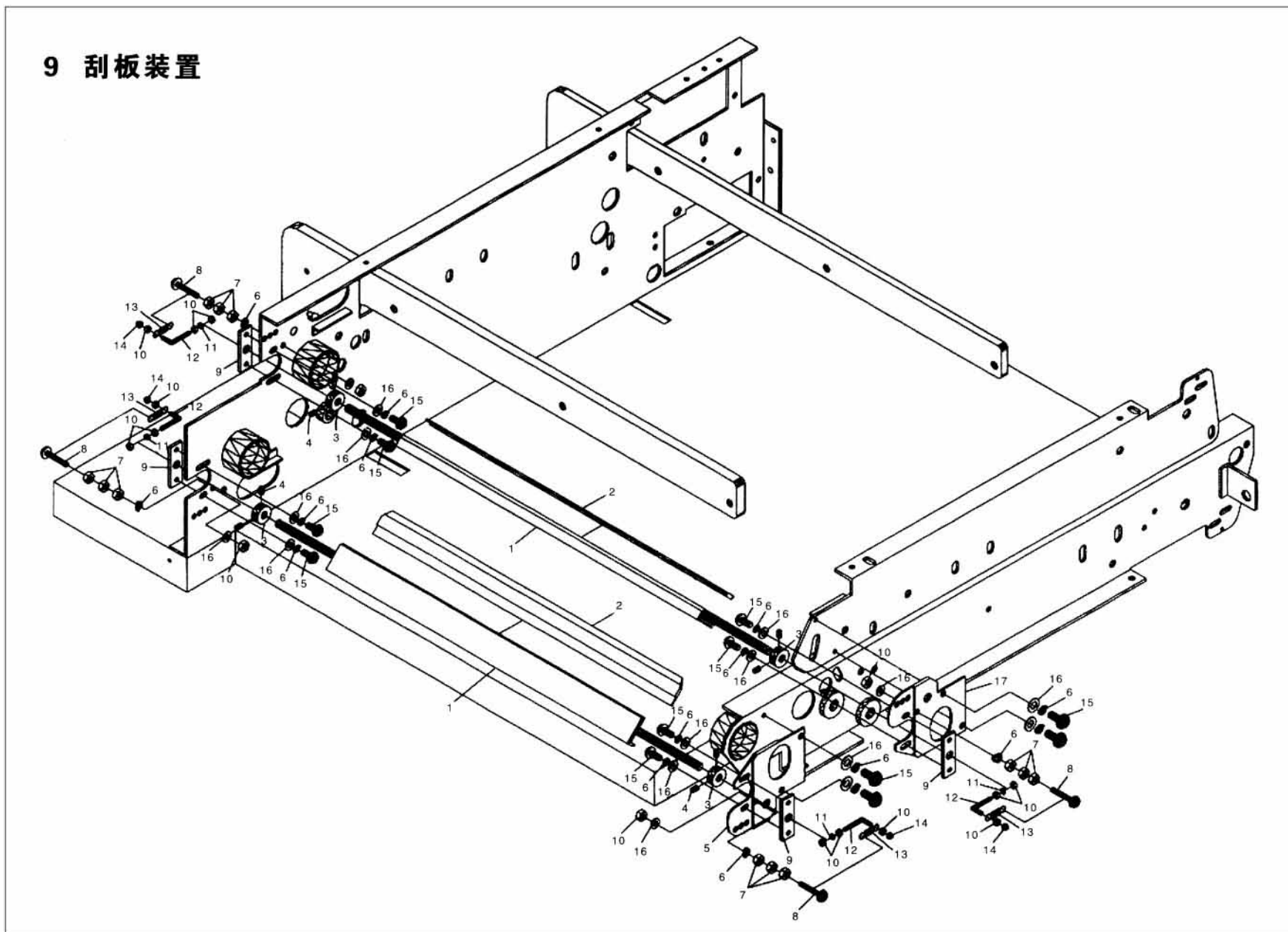

41

### 10 电装

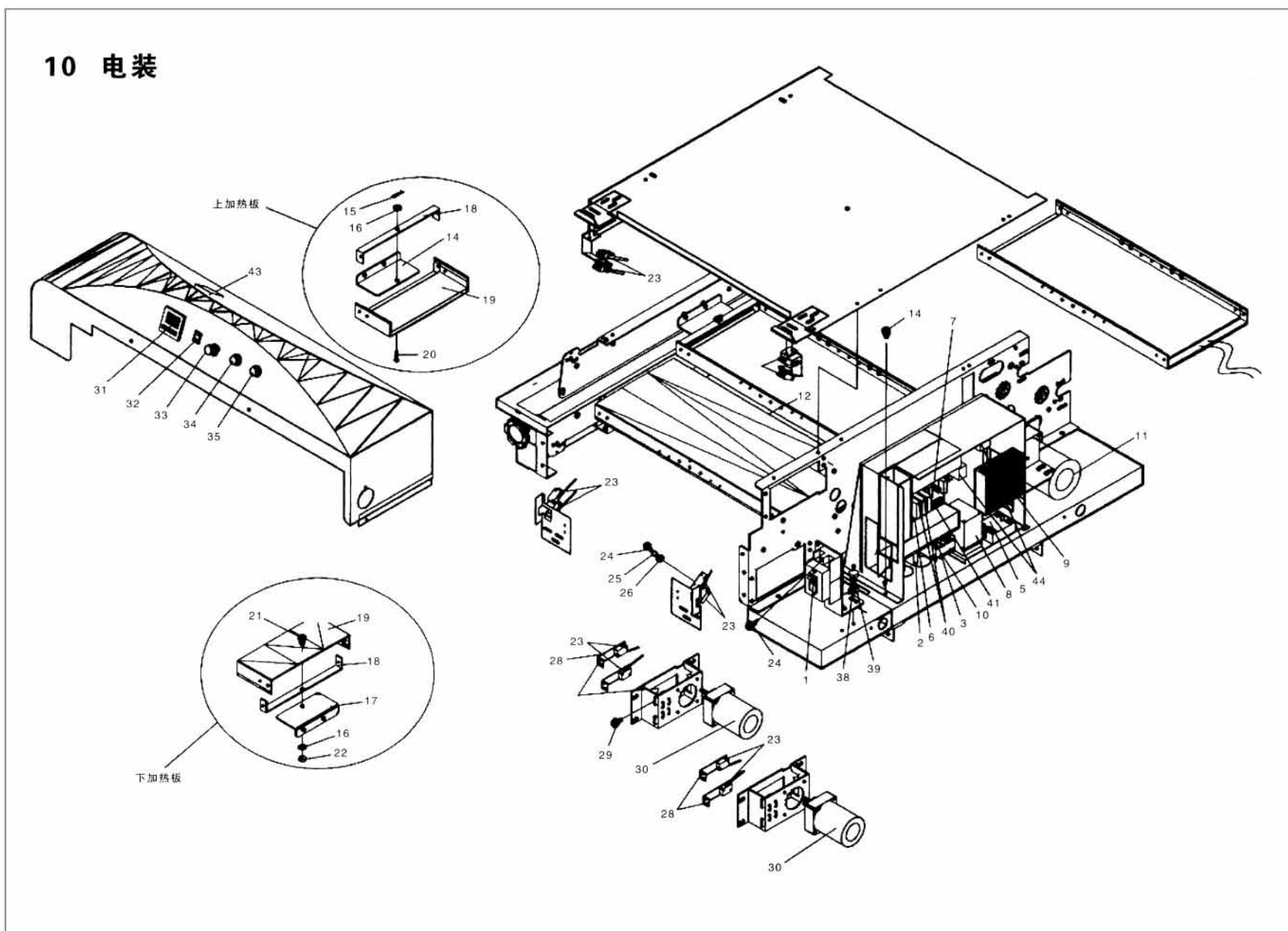

42









## 6. 皮带张紧部分

序号	部品编号	部品名	Parts name	Q'ty	备注
1	WJ-450M06001	张紧罗拉	tension roller	2	
2	WJ-450M06002	轴承	bearing	16	6202ZC4
3	WJ-450M06003	卡簧(φ15)	c-ring	20	
4	WJ-450M06004	张紧用弹簧	tension spring	4	
5	WJ-450M06005	内六角圆柱头螺丝 M6*30	hex holed screw	4	
6	WJ-450M06006	六角螺母 M6	hex nut	8	
7	WJ-450M06007	平垫圈 M6	plain washer	4	
8	WJ-450M06008	标准型弹簧垫圈 M6	spring washer	4	
9	WJ-450M06009	剥离器安装板下	blade stay(lower)	1	
10	WJ-450M06010	剥离器安装板上	blade stay(upper)	1	
11	WJ-450M06011	平垫圈 M5	plain washer	4	
12	WJ-450M06012	标准型弹簧垫圈 M5	spring washer	4	
13	WJ-450M06013	十字盘头螺丝 M5*10	pan screw	4	
14	WJ-450M06014	平垫圈 M8	plain washer	8	
15	WJ-450M06015	标准型弹簧垫圈 M8	spring washer	8	
16	WJ-450M06016	外六角螺丝 M8*20	hex screw	8	
17	WJ-450M06017	并行罗拉	roller	4	
18	WJ-450M06018	铁氟龙皮带(下)	teflon belt(lower)	1	
19	WJ-450M06019	铁氟龙皮带(上)	teflon belt(upper)	1	
20	WJ-450M06020	张紧罗拉轴	tension roller shaft	2	
21	WJ-450M06021	并行罗拉轴	roller shaft	4	

51

## 7. 回转剥离装置 (表一)

序号	部品编号	部品名	Parts name	Q'ty	备注
1	WJ-450MS07001	剥离回转轴同螺钉侧压板	brade stopper	4	
2	WJ-450MS07002	旋转玻璃刮板	rotary strip off brade	8	
3	WJ-450MS07003	剥离回转轴带螺纹压板	rotary shaft stopper side	4	
4	WJ-450MS07004	内六角圆柱头螺丝 M5*15	hex holed screw	8	
5	WJ-450MS07005	标准型弹簧垫圈 M5	spring washer	12	
6	WJ-450MS07006	带座轴承	pyro	4	SU08
7	WJ-450MS07007	清洗用方管	cleaner pipe	2	
8	WJ-450MS07008	清洗用方管螺母	pipe end metal	2	
9	WJ-450MS07009	六角螺母 M8	hex nut	4	
10	WJ-450MS07010	标准型弹簧垫圈 M8	spring washer	2	
11	WJ-450MS07011	平垫圈 M8	plain washer	6	
12	WJ-450MS07012	平垫圈 M10	plain washer	4	
13	WJ-450MS07013	平垫圈 M6	plain washer	6	
14	WJ-450MS07014	标准型弹簧垫圈 M6	spring washer	2	
15	WJ-450MS07015	六角螺母 M6	hex nut	3	
16	WJ-450MS07016	无油轴承	metal	1	WC8*16*1.5
17	WJ-450MS07017	剥离张紧轮固定件	strip-off tension stay	1	
18	WJ-450MS07018	无油轴承	metal	1	06070
19	WJ-450MS07019	无油轴承	metal	3	WC6.4*12*1.5
20	WJ-450MS07020	外六角螺丝 M6*20	hex screw	1	
21	WJ-450MS07021	十字沉头螺丝 M8*50	raund head screw	1	
22	WJ-450MS07022	剥离固定件	strip-off fixing stay	4	
23	WJ-450MS07023	回转剥离链轮	rotary blade sprocket	2	
24	WJ-450MS07024	内六角凹端紧定螺钉 M5*5	hex holed set screw	4	
25	WJ-450MS07025	链条	chain	1	25#
26	WJ-450MS07026	无油轴承	metal	2	06040
27	WJ-450MS07027	回转剥离张紧链轮	rotary strip-off tension sprocket	1	
28	WJ-450MS07028	内六角圆柱头螺丝 M6*40	hex holed screw	1	

52





